

ATTEN

Product Catalog 2025



ABOUT US

Shenzhen ATTEN Technology Co., Ltd started from 1996 and established in 1999.

We are a professional manufacturer of producing soldering equipment over 27 years.

We are located in Shenzhen with convenient transportation access. ATTEN got the ISO 9001:2015 international quality system authentication and won the National High-tech Enterprise, Shenzhen Top Brand and a number of honorary titles. ATTEN products have got approvals off “**CE, RoHS2.0, UKCA, REACH, ETL, KC, FCC, SAA, CSA, NOM**”and other qualifications. We provide 2 years quality guarantee for main unit, and specialized after-sales service. ATTEN sells our own brand products and also welcome OEM orders. Whether selecting a current product from our catalog or seeking engineering assistance for your application, you can contact our customer service center for your sourcing requirements. Welcome to be our partner!

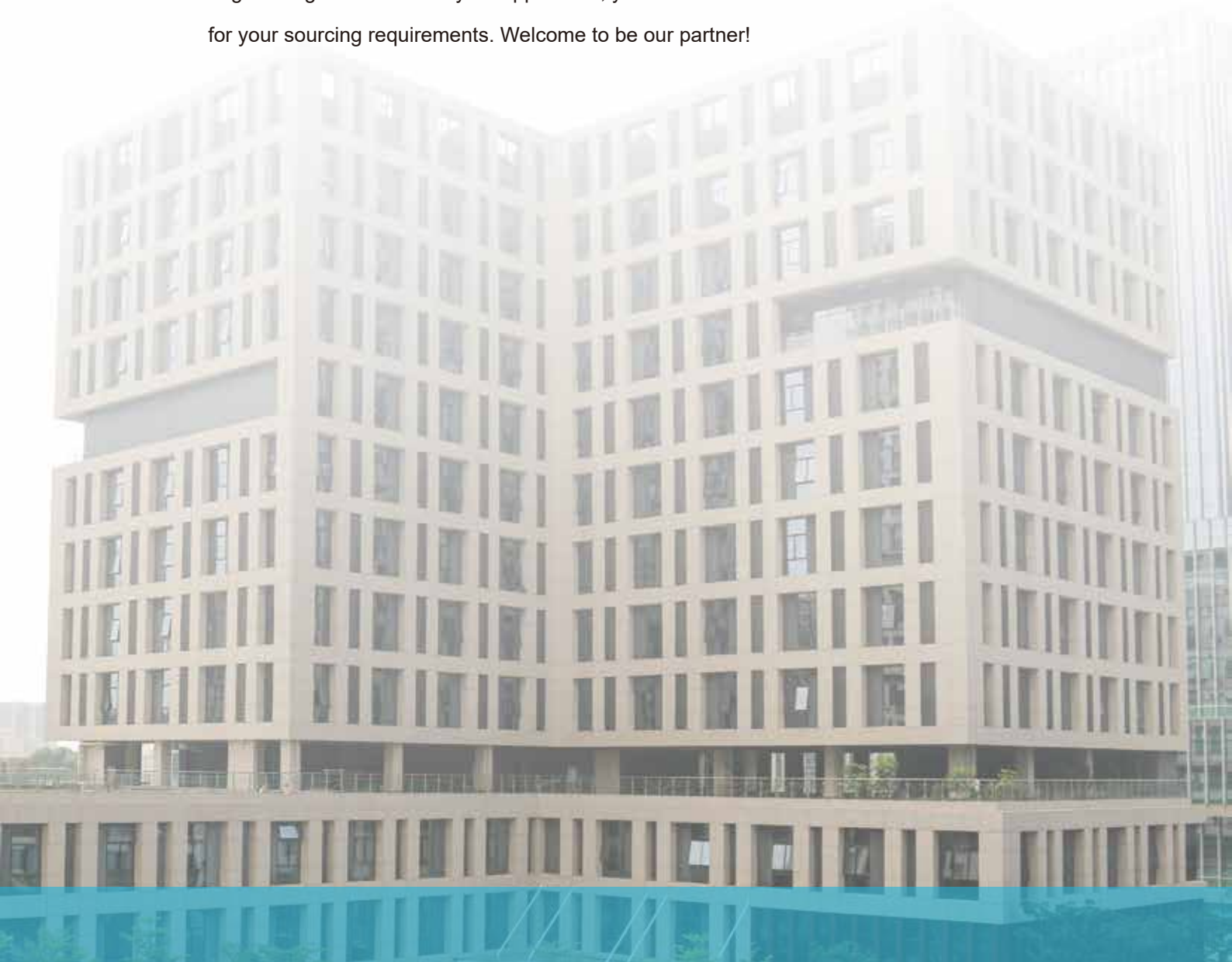

New



GT-6500P

High-Power Soldering Station



GT-Y500 handle 500W (compatible with T473 series integrated heating)

GT-Y300 handle (compatible with T156 series integrated heating 150W)

- With a super high power of 500W and high thermal conductivity, it remains stable even after 24 hours of continuous soldering.
- 150W/500W dual-power soldering iron ports, one machine for multiple purposes, making it more convenient.
- ESD grounding detection alarm and temperature deviation alarm, more responsive.
- The brand-new three-core heating element solution heats up quickly and recovers quickly and stably.
- ESD safe protection, anti-static design for the entire machine, ensuring worry-free soldering.
- Three preset temperatures, customization, fast switching, and high efficiency.

New

ZT-661-200H

Single Axis Semi-Automatic Soldering Robot



- Touch screen control, easy to debug and operate.
- Automatic cleaning, air pump for blowing and cleaning.
- Just need to replace the fixture, can weld different products.
- With foot switch control mode and automatic control mode.
- Automatic cleaning of soldering iron tip, high soldering efficiency.
- Metal handle and heating element, high temperature resistance.

New



GT-6090/GT-6120

High-Precision & Intelligent Soldering Station

GT-N080 40W*2
(The T210N series integrated heating can be used)

S-27 tweezer stand



GT-6090 host
(single channel 90W)



GT-6120 host
(dual-channel 130W)



S-26 soldering iron stand



GT-Y040 soldering iron handle 40W
(T210 series integrated heating can be used)

- Supports switching between 2 types of soldering irons/electric tweezers.
- It takes only 4 seconds to heat up from room temperature to 380 degrees, with fast heating and higher soldering efficiency.
- The soldering iron handle is more compact, specifically designed for precision soldering of micro components.
- ESD grounding detection alarm and temperature deviation alarm, making it more sensitive.
- Supports instant hibernation & customizable hibernation mode, enhancing the lifespan of the soldering iron tip.
- Patented product, more trustworthy.

New

High-Efficiency Preheater Platform



120x120mm

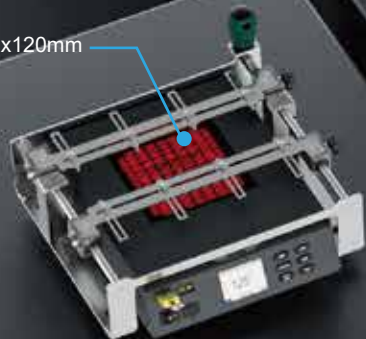

ST-7700

180x200mm*4



ST-7322

120x120mm*4

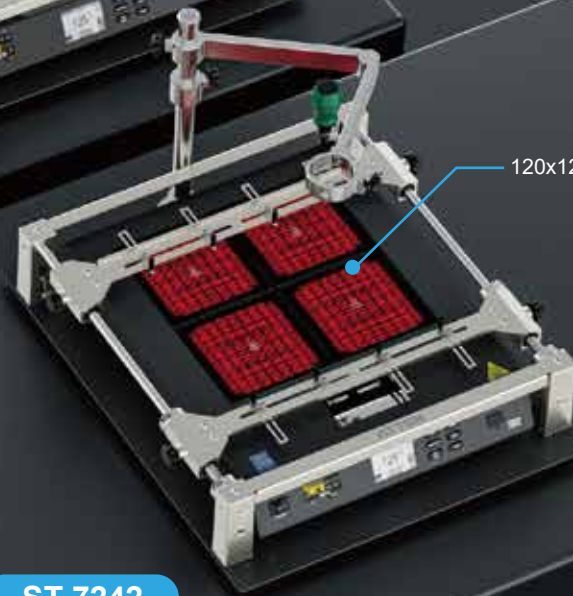

ST-7242

- 4-channel sensor interface, multi-point monitoring, over-temperature protection, ensuring greater safety.
- The heating speed can be customized, ensuring a more stable and safer heating process.
- Can be combined with a preheating bracket to form a rework station, adapting to more scenarios.
- Equipped with an RS485 interface, it can be integrated into the MES system, empowering smart manufacturing.
- ESD safety protection, with an anti-static design for the entire machine, ensuring worry-free soldering.
- Introducing a new curve temperature control function to facilitate standardized operations.

Patented Soldering Iron Tip Cleaner



New

GT-6081

Power: 5W

Motor speed: 250-350 rpm



GT-6080

Power: 15W

Motor speed: 500-1000 rpm



- Driven by a brushless motor, it boasts high speed, silent operation, and doubled lifespan.
- Replaceable brush head, significantly reducing consumable costs.
- MCU microprocessor, non-contact induction, start-stop function, more worry-free.
- ESD safety protection, with anti-static design for the entire machine, ensuring worry-free soldering.
- 12V low voltage, ensuring safer operation in humid environments.
- Brush head stall protection, ensuring safety and durability.

Contents

Soldering Station

■ GT-6150P,GT-6200P,GT-5150P,GT-5200P Intelligent Soldering Station	02
■ GT-6300P,GT-6500P High Power Intelligent Soldering Station	05
■ GT-6090,GT-6120 High-Precision Intelligent Soldering Station	08
■ GT-6301,GT-6302 High-Power Intelligent Soldering Station	10
■ ST-1503D+,ST-9003D,ST-1303D,ST-3003D Heavy Duty Soldering Station	12
■ ST-1509 Soldering Station	15
■ ST-909 Soldering Station	17
■ ST-60,ST-80 Soldering Station	18
■ ST-100 Digital Soldering Station	19

Soldering Iron

■ GT-2010+ USB Soldering Iron	21
■ ST-2065D,ST-2080D,ST-2150D Digital Soldering Iron	22

Automatic Equipment

■ ZT-664-4030 Four-axis Automatic Soldering Robot	25
■ ZT-661-200H Single Axis Semi-Automatic Soldering Robot	27
■ ZT-660-150G Auto-Feed Soldering Station	29

Hot Air Station

■ GT-1028,GT-8100A Intelligent Hot Air Rework Station	32
■ ST-862D Hot Air Station	33
■ ST-8800D Hot Air Station	34
■ ST-2308DX Heat Gun	36

Rework Station

■ MS-900 4 In 1 Intelligent Rework Station	38
■ MS-500 3 In 1 Rework Station	40
■ ST-8902D 2 In 1 Rework Station	41
■ ST-8802 2 In 1 Rework Station	42

Thermal Wire Stripper

■ ST-680D Thermal Wire Stripper	44
---------------------------------------	----

Preheating Platform

■ ST-7500,ST-7800 Preheater	47
■ ST-7242,ST-7322 Preheater	48
■ ST-7700 Preheater	49

Fume Purification

■ ST-1101,ST-1101D,ST-1202,ST-1202D Fume Extractor	51
■ ST-1016 Smoke Absorber	53

ESD Protection

■ ST-1020D,ST-1020DX,ST-1015,ST-1015W Static Eliminator Ion Fan	55
■ AT-FJ1,AT-FJ2 Wrist Strap	56
■ AT-518-1,AT-518-2 Wrist Strap Monitor	56

Tool Accessories

■ GT-6081,GT-6080 Tip Cleaner	58
■ ST-1090 Temperature tester	59
■ JQ-010,JQ-050,JQ-100A Hot Melting Glue Gun	60
■ LT-360B,LT-350B,LT-380B,LT-310B Solder Pot	60
■ S-11 Solder Iron stand,CS-05B Tip Cleaner,CS-08B Solder Dross Box	61
■ FT-90A Magnifying Frame	61
■ TJ-227,TJ-228,TJ-227A,TJ-227B Solder Wire Stand	61
■ TR-045 Rosin Flux,AT-F10 Tip Refresher	61
■ AT-H20,AT-H40,AT-H60 Paste Flux	61
■ AT-E330A,AT-E330P,AT-E210D Desoldering Tool	61
■ AT-B778 Vacuum Pick-up Tool	61
■ Soldering Wire	62
■ Soldering Wick	63

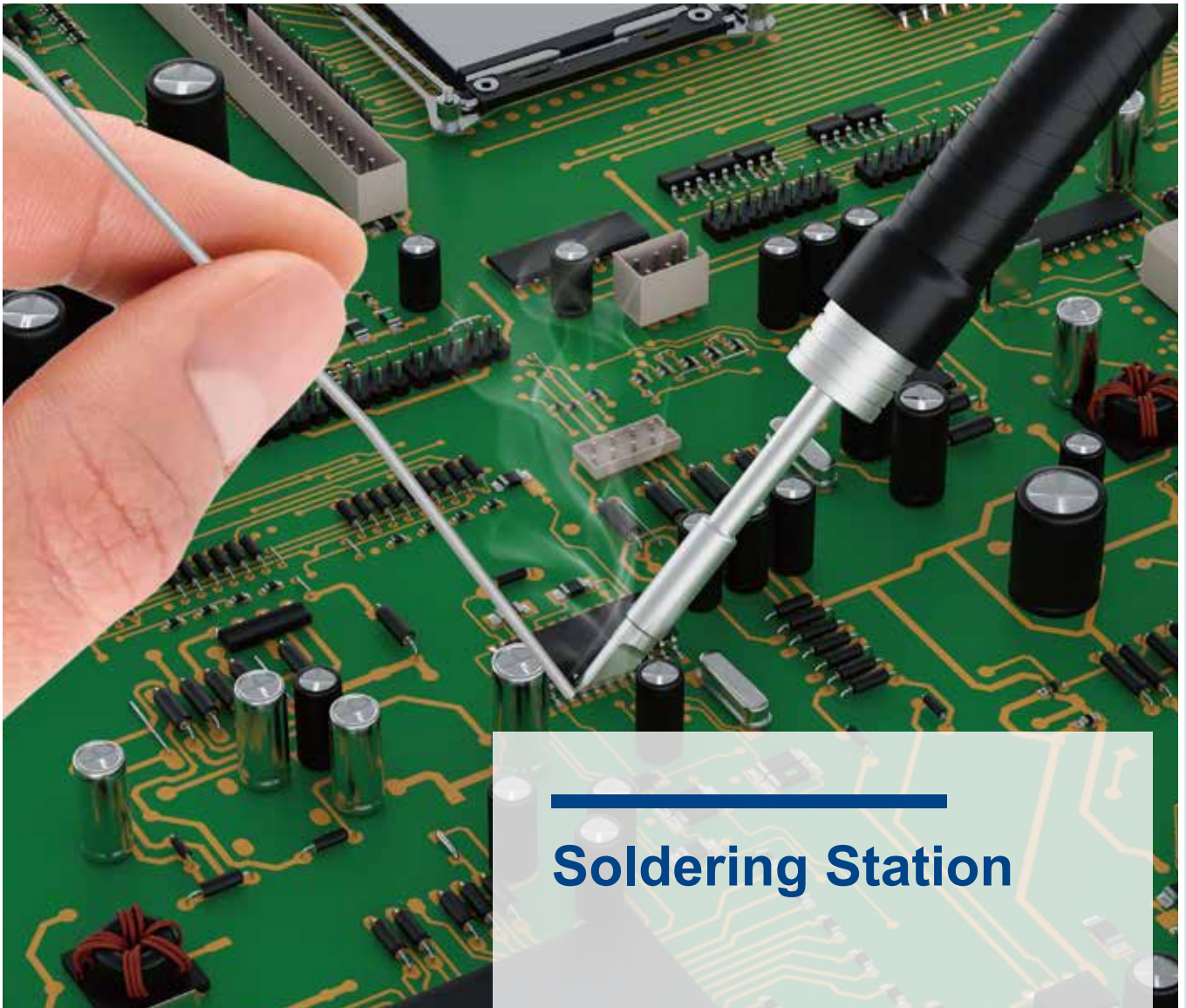

Soldering Station



Tài liệu được tổng hợp bởi đội ngũ kỹ thuật của **NPOWER**
Bản quyền nội dung thuộc về **Atten**

Powered by **NAVITECH** | www.navitech.co
www.npower.com.vn

■ GT-6150P,GT-6200P,GT-5150P,GT-5200P Intelligent Soldering Station	02
■ GT-6300P,GT-6500P High Power Intelligent Soldering Station	05
■ GT-6090,GT-6120 High-Precision Intelligent Soldering Station	08
■ GT-6301,GT-6302 High-Power Intelligent Soldering Station	10
■ ST-1503D+,ST-9003D,ST-1303D,ST-3003D Heavy Duty Soldering Station	12
■ ST-1509 Soldering Station	15
■ ST-909 Soldering Station	17
■ ST-60,ST-80 Soldering Station	18
■ ST-100 Digital Soldering Station	19

GT-6150P/GT-6200P/GT-5150P/GT-5200P



Intelligent Soldering Station

Features

- Adopting TFT large screen, rich and intuitive graphic display.
- Automatically recognize the soldering tools and upload the corresponding parameters.
- The curve work interface allows you to view the temperature and power curves of the current tool.
- Supports RS-485 and USB communication interfaces, and parameters can be set through the upper computer software.

Specification

Model (Host)	GT-6150	GT-6200
Voltage	AC 230V±10% 50Hz (110V±10% 60Hz)	
Power	150W	200W
Tool Channel	Single Channel	Dual Channel
Heating Principle	Resistance Heating	
Temperature Range	80~500°C	
Temperature Compensation	±50°C	
IoT Function	RS485	
Tip to Ground Resistance	≤2Ω	
Dimensions	230(L)x142(W)x145(H)mm	
Weight	≈3.2 kg	

Package List

Set	Packing List
GT-6150P	GT-6150 Host GT-Y130P S-19
GT-6200P	GT-6200 Host GT-Y130P S-19 GT-N100P S-20
GT-5150P	GT-6150 Host GT-X150P S-21
GT-5200P	GT-6200 Host GT-Y130P S-19 GT-X150P S-21

*Consumable accessory package x1

Solder Suction x3	O-Ring Seal x2	Inner Pipe(Carbon Spring) x1	Cleaning Pin Set x1
Cleaning Pin x2	Filter Cotton x10	High temperature sealant plug x2	
Twist Drill x1	Filter Paper x10	Open-end Spanner x1	

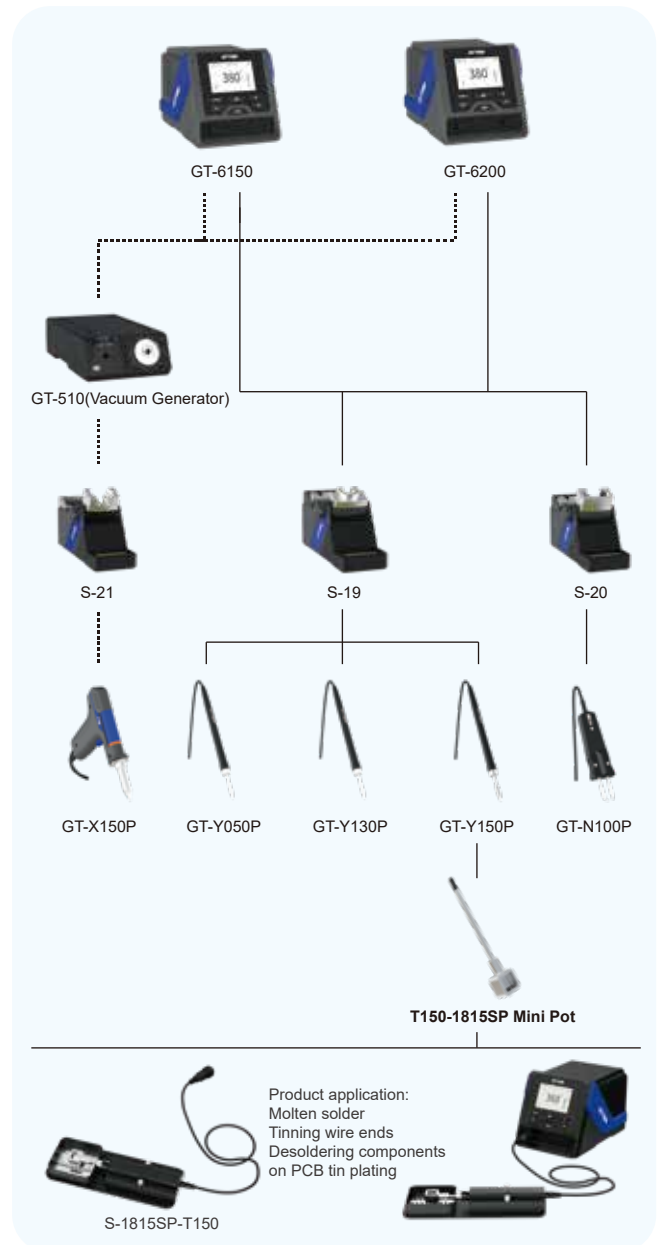

GT Series Soldering Iron Heating Test

(Use T130-1.0I soldering iron tip)

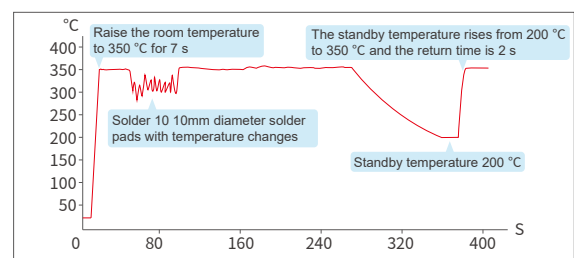

Communication Function

RS485 interface

Connect the computer, set various parameters through the upper computer software, and display the temperature curve.

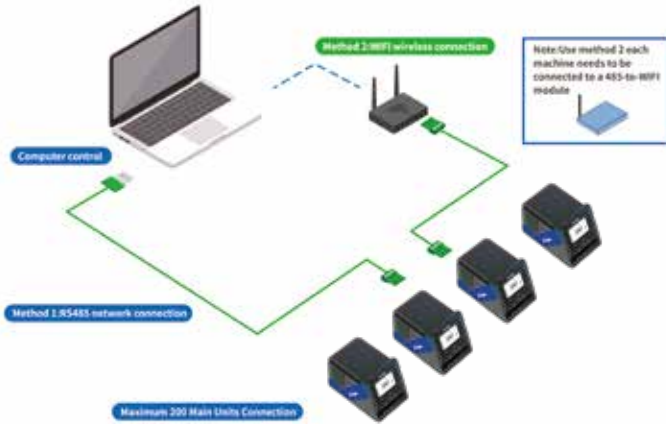

Standby Function

After connecting the soldering iron holder to the host with a connecting wire, the standby function will be activated when the handle is placed on the soldering iron holder, which is convenient and safe, reduces the oxidation of the soldering iron tip, and extends the lifespan of the soldering iron tip.



Support collaboration with Atten smoke purifiers.

Linkage Function

Types of Handle

GT-Y050P



50W mini soldering iron, suitable for small soldering components.
(Using T50 series integrated soldering tip)

GT-Y130P



130W middle size soldering iron, suitable for most soldering components.
(Using T130 series integrated soldering tip)

GT-Y150P



150W soldering iron, suitable for soldering oversized pads and large workpieces.
(Using T150 series integrated soldering tip)

GT-N100P

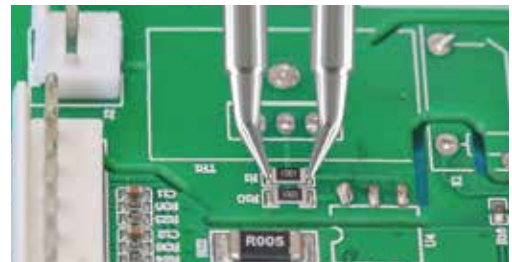

100W electric tweezers, suitable for soldering and desoldering various SMD devices.
(Using T100 series integrated electric tweezers)

Temperature control of integrated soldering tip

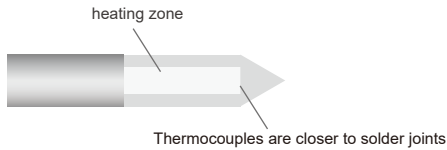

High thermal conductivity soldering tip

The heating system is located close to the soldering iron tip, which can quickly detect the heat loss of the soldering iron tip. The temperature will return quickly.

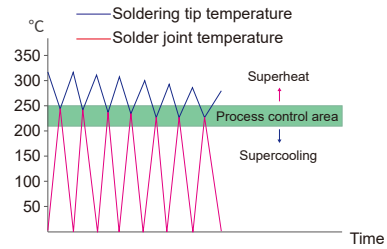

Each solder joint can be completed within the process control area to prevent cold welding!

Desoldering Gun

GT-X150P

150W Desoldering gun, ultra high power, fast heating, minimizes damage to PCB board to the greatest extent possible. Newly designed replaceable suction nozzle, fast thermal conductivity, high efficiency and low cost.

(Using T151 series tin suction nozzle)

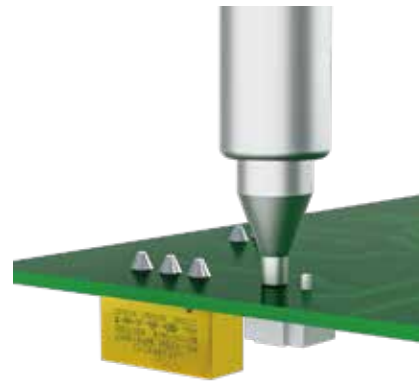

Note: GT-X150P tin suction gun, temperature range: 350~500 °C.

Soldering Iron Stand



S-19
Iron stand



S-20
Tweezers stand



S-21
Desoldering gun stand



Vacuum Generator



GT-510(Vacuum Generator)

Model	GT-510
Power	60W
External communication interface	RJ12
Vacuum degree	-80KPa
Air flow	36L/min(MAX)
Tin blockage alarm function	support
Filter paper replacement	support
Dimensions	140 (L) x255 (W) x70 (H) mm
Weight	≈1.4kg

Optional Tips

T50 (Applicable model: GT-6150P GT-6200P GT-5150P GT-5200P MS-900)

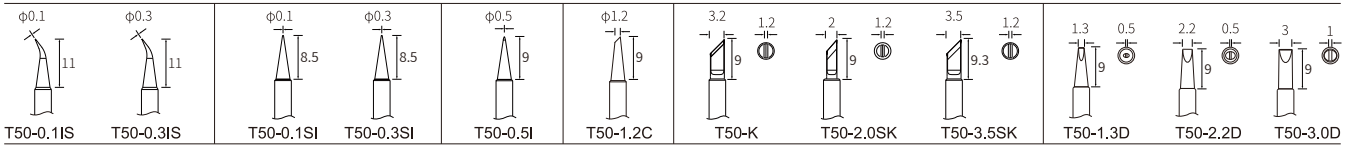

T100 (Applicable model: GT-6150P GT-6200P GT-5150P GT-5200P MS-900)

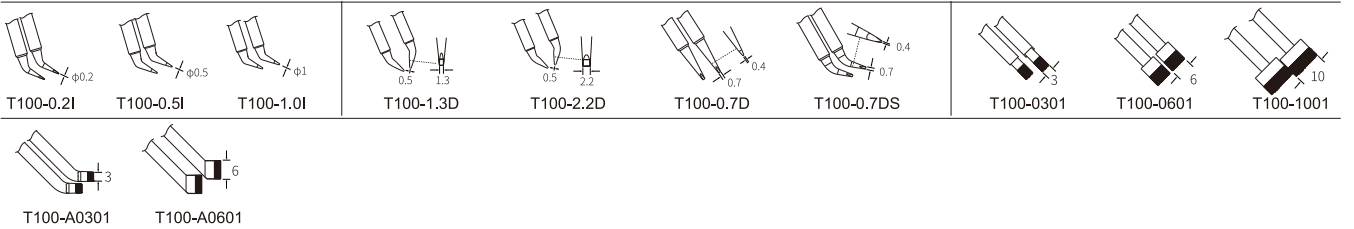

T130 (Applicable model: GT-6150P GT-6200P GT-5150P GT-5200P MS-900)

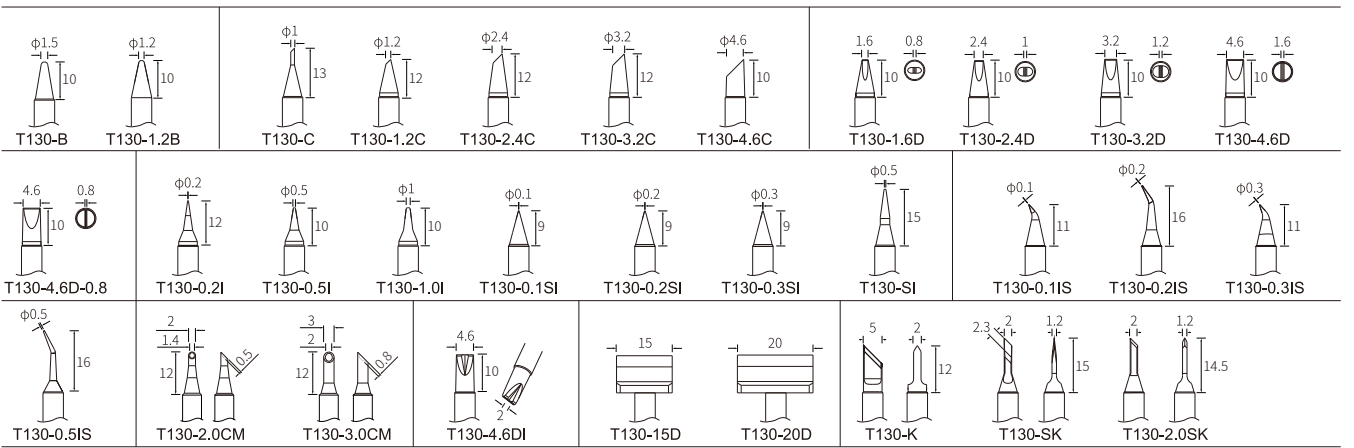

T150 (Applicable model: GT-6150P GT-6200P GT-5150P GT-5200P MS-900)

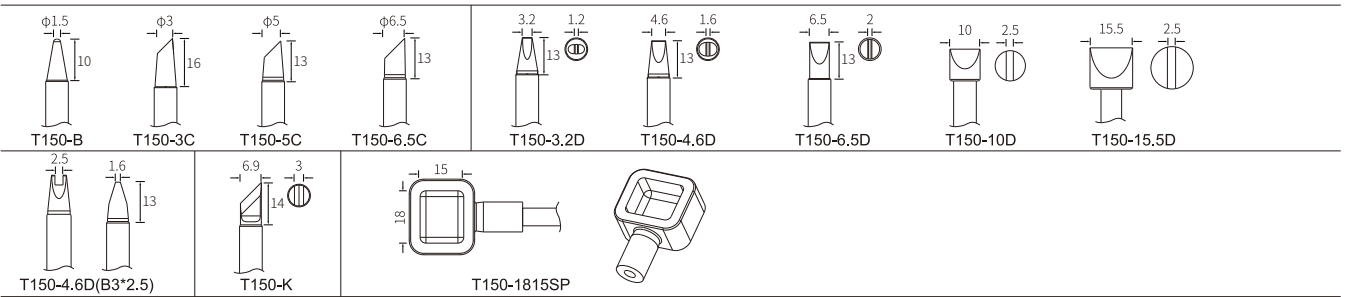

Desoldering Nozzles

T151 (Applicable model: GT-5150P GT-5200P MS-900)

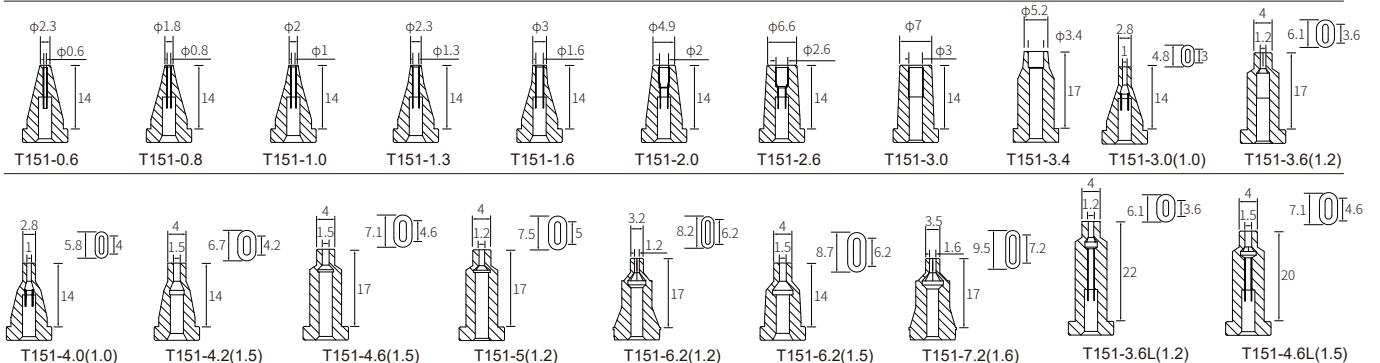

GT-6300P/GT-6500P

ESD SAFE

High Power Intelligent Soldering Station

Features

- Adopting TFT large screen, rich and intuitive graphic display.
- Automatically recognize the soldering tips and upload the corresponding parameters.
- The curve work interface allows you to view the temperature and power curves of the current tool.
- Supports RS-485 and USB communication interfaces, and parameters can be set through the upper computer software.

Specification

Model (Host)	GT-A300	GT-A500
Voltage	AC 230V±10% (110V±10%)	AC 230V±10%
Power	300W	520W
Tool Channel	Single Channel	
Handle Mode	GT-Y300	GT-Y500
Heating Principle	Resistance Heating	
Temperature Range	80~500°C	
Temperature Compensation	±50°C	
IoT Function	RS485	
Tip to Ground Resistance	≤2Ω	
Tip-to-ground Potential	≤2mV	
Dimensions	230(L)x142(W)x145(H)mm	
Weight	≈4.4 kg	≈5.3 kg

Package List

Set	Host model	Packing List
GT-6300P	GT-A300	Single-channel Main Unit x1 GT Series Handle x1 Soldering Iron Stand x1 Connection Line x1 Grounding Wire x1 Power Cord x1 User Manual x1 Certificate x1
GT-6500P	GT-A500	



Standby Function

After connecting the soldering iron holder to the host with a connecting wire, the standby function will be activated when the handle is placed on the soldering iron holder, which is convenient and safe, reduces the oxidation of the soldering iron tip, and extends the lifespan of the soldering iron tip.



Support collaboration with Atten smoke purifiers.

Linkage Function

Communication Function

RS485 interface

Connect the computer and set various parameters through the upper computer software.



Remote process control

Soldering iron Handle



GT-Y300 Soldering iron Handle
(Can use T156 Series Integrated heater and T470 Series Integrated heater)



GT-Y500 Soldering iron Handle
(Can use T156 Series Integrated heater and T473 Series Integrated heater)



T156 Series Integrated heater (150W)



T470 Series Integrated heater (300W)



T473 Series Integrated heater (500W)

Note: The GT-6500P, when paired with the GT-Y300 handle, can only use the T156 series integrated heater.

Optional Tips

T156 (Applicable model: GT-6300P/GT-6500P)



T156-0.4IS

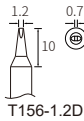

T156-1.2D

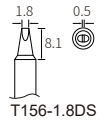

T156-1.8DS

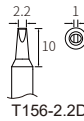

T156-2.2D

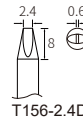

T156-2.4DS

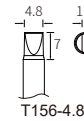

T156-4.8DS

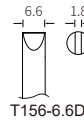

T156-6.6DS

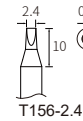

T156-2.4DT

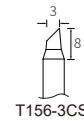

T156-3CS

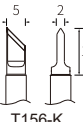

T156-K

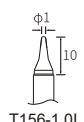

T156-1.0I

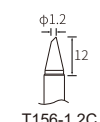

T156-1.2C

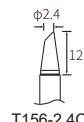

T156-2.4C

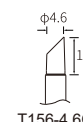

T156-4.6C

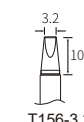

T156-3.2D

T470 (Applicable model: GT-6300P)

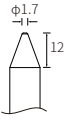

T470-B



T470-4D

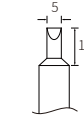

T470-5D



T470-6D



T470-7.5D

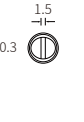

T470-8.5D

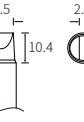

T470-10D

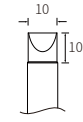

T470-15.5D

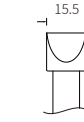

T470-15.5D

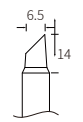

T470-6.5C

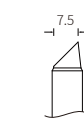

T470-7.5C



T470-10C



T470-K

T473 (Applicable model: GT-6500P)

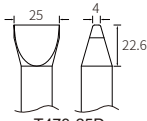

T473-25D

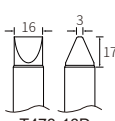

T473-16D

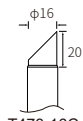

T473-16C

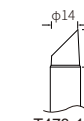

T473-14C



T473-12C

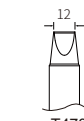

T473-12D

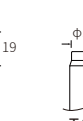

T473-15P

GT-6090/GT-6120 ESD SAFE

High-Precision Intelligent Soldering Station

Features

- Adopting TFT large screen, rich and intuitive graphic display.
- Automatically recognize the soldering tips and upload the corresponding parameters.
- The curve work interface allows you to view the temperature and power curves of the current tool.
- Supports RS-485 and USB communication interfaces, and parameters can be set through the upper computer software.

Specification

Model (Host)	GT-6090	GT-6120
Voltage	AC 230V±10% 50Hz (110V±10% 60Hz)	
Power	90W	130W
Tool Channel	Single Channel	Dual Channel
Handle Mode	GT-Y040 Soldering Iron/GT-N080 Tweezer	
Heating Principle	Resistance Heating	
Temperature Range	80~500°C/176~932°F	
Temperature Compensation	±50°C/±122°F	
IoT Function	RS485	
Tip to Ground Resistance	≤2Ω	
Tip-to-ground Potential	≤2mV	
Dimensions	105(L)x170(W)x110(H)mm	
Weight	≈2.4kg	

Package List

Host model	Packing List
GT-6090	Host x1 Power cord x1 Ground wire x1 Soldering iron holder connection wire x1 USB 2.0 cable x1 Certificate of conformity x1 User manual x1
GT-6120	Host x1 Power cord x1 Ground wire x1 Soldering iron holder connection wire x2 USB 2.0 cable x1 Certificate of conformity x1 User manual x1

Set	Product Introduction
GT-6090A	 → 
GT-6090B	 → 
GT-6120A	 → 
GT-6120B	 → 
GT-6120C	 → 



Standby Function

After connecting the soldering iron holder to the host with a connecting wire, the standby function will be activated when the handle is placed on the soldering iron holder, which is convenient and safe, reduces the oxidation of the soldering iron tip, and extends the lifespan of the soldering iron tip.

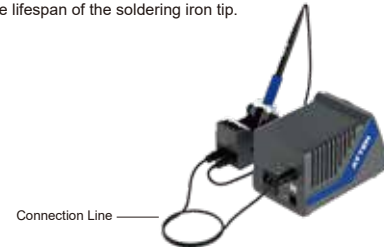

Support collaboration with Atten smoke purifiers.

Linkage Function

Communication Function

RS485 interface

Connect the computer and set various parameters through the upper computer software.



Remote process control

Types of Handle



GT-Y040手柄



GT-N080手柄



(Using T210 series integrated soldering tip)

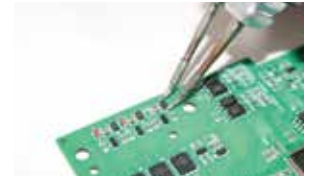

(Using T210N series integrated soldering tip)

Soldering Iron Stand



S-26
Iron stand



S-27
Tweezers stand



Optional Tips

T210

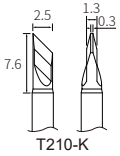
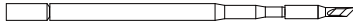

T210-K

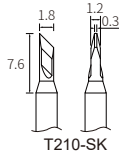

T210-SK

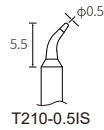

T210-0.5IS

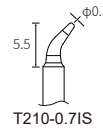

T210-0.7IS

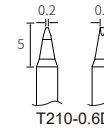

T210-0.6D

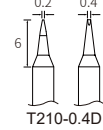

T210-0.4D

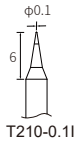

T210-0.1I

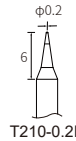

T210-0.2I

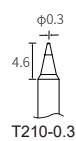

T210-0.3I



T210-0.6I

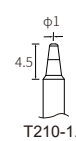

T210-1.0I

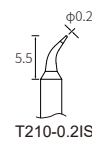

T210-0.2IS

T210N

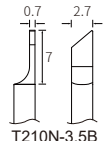

T210N-3.5B

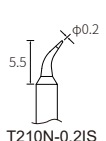

T210N-0.2IS

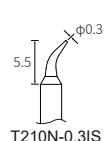

T210N-0.3IS

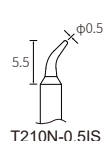

T210N-0.5IS

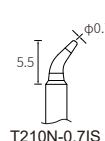

T210N-0.7IS

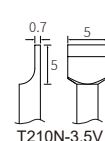

T210N-3.5V

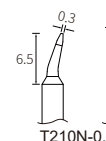

T210N-0.6DS



Tài liệu được tổng hợp bởi đội ngũ kỹ thuật của NPOWER
Bản quyền nội dung thuộc về Atten

Powered by NAVITECH | www.navitech.co
www.npower.com.vn

GT-6301/GT-6302 ESD SAFE

High-Power Intelligent Soldering Station

Features

- Adopting TFT large screen, rich and intuitive graphic display.
- Automatically recognize the soldering tools and upload the corresponding parameters.
- The real-time data collection allows you to view the temperature and power curves of the current tool.
- Supports RS-485 and USB communication interfaces, and parameters can be set through the upper computer software.

Specification

Model (Host)	GT-6301	GT-6302
Voltage	AC 120V~ 60Hz	
Power	150W	300W
Tool Channel	Single Channel	Dual Channel
Heating Principle	Resistance Heating	
Temperature Range	80~500°C/176~932°F	
Temperature Compensation	±50°C/±122°F	
IoT Function	RS485	
Tip to Ground Resistance	≤2Ω	
Tip-to-ground Potential	≤2mV	
Dimensions	230(L)x142(W)x145(H)mm	
Weight	≈4.5 kg	

Package List

Set	Packing List
GT-6301A	 
GT-6301B	 
GT-6302A	 
GT-6302B	 
GT-6302C	 

*Consumable accessory package x1

Solder Suction x3	O-Ring Seal x2	Inner Pipe(Carbon Spring) x1	Cleaning Pin Set x1
Cleaning Pin x2	Filter Cotton x10	High temperature sealant plug x2	
Twist Drill x1	Filter Paper x10	Open-end Spanner x1	

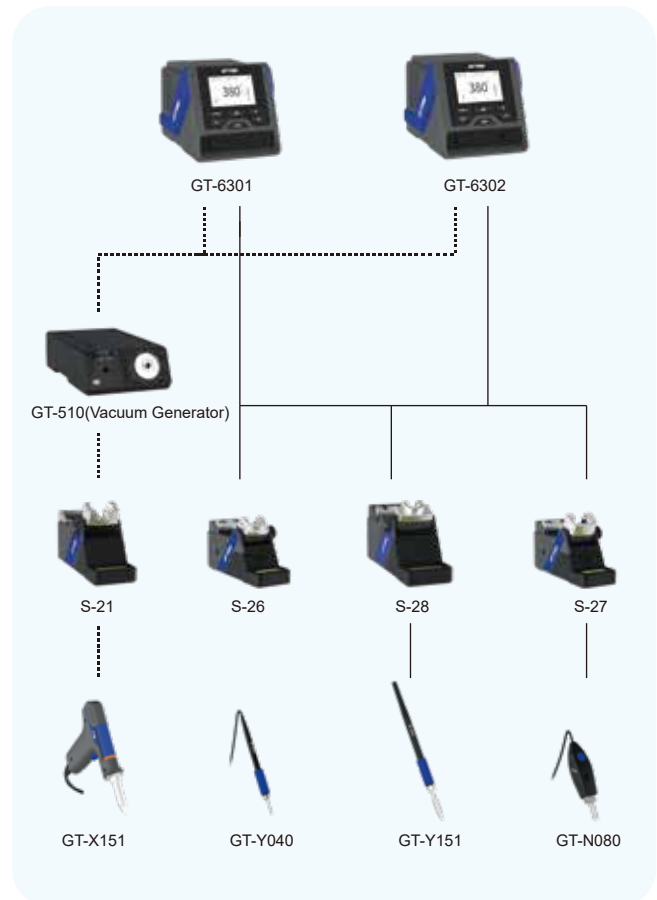

Standby Function

After connecting the soldering iron holder to the host with a connecting wire, the standby function will be activated when the handle is placed on the soldering iron holder, which is convenient and safe, reduces the oxidation of the soldering iron tip, and extends the lifespan of the soldering iron tip.



Support collaboration with Atten smoke purifiers.

Linkage Function

Vacuum Generator



GT-510(Vacuum Generator)

Model	GT-510
Power	60W
External communication interface	RJ12
Vacuum degree	-80KPa
Air flow	36L/min(MAX)
Tin blockage alarm function	support
Filter paper replacement	support
Dimensions	140 (L) x255 (W) x70 (H) mm
Weight	≈1.4kg

Soldering iron Handle



GT-Y151 Soldering iron Handle
(Can use T156 Series Integrated heater)
T156 series soldering tip in page 07.



GT-Y040 Soldering Iron
(Using T210 Cartridge-type tip)
T210 series soldering tip in page 09.



GT-N080 Tweezer
(Using T210N Cartridge-type tip)
T210N series soldering tip in page 09.

Desoldering Gun

GT-X151

150W Desoldering gun, ultra high power, fast heating, minimizes damage to PCB board to the greatest extent possible. Newly designed replaceable suction nozzle, fast thermal conductivity, high efficiency and low cost.

(Using T151 series tin suction nozzle)

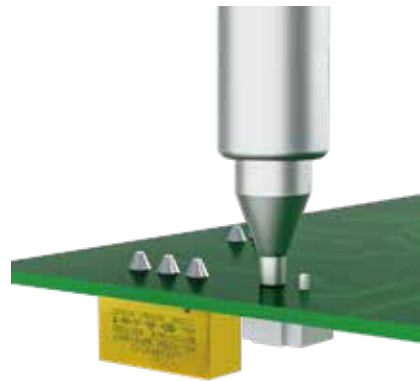

Note: GT-X151 tin suction gun, temperature range: 350~480 °C.

Desoldering Nozzles

T151 (Applicable model: GT-6301 GT-6302)

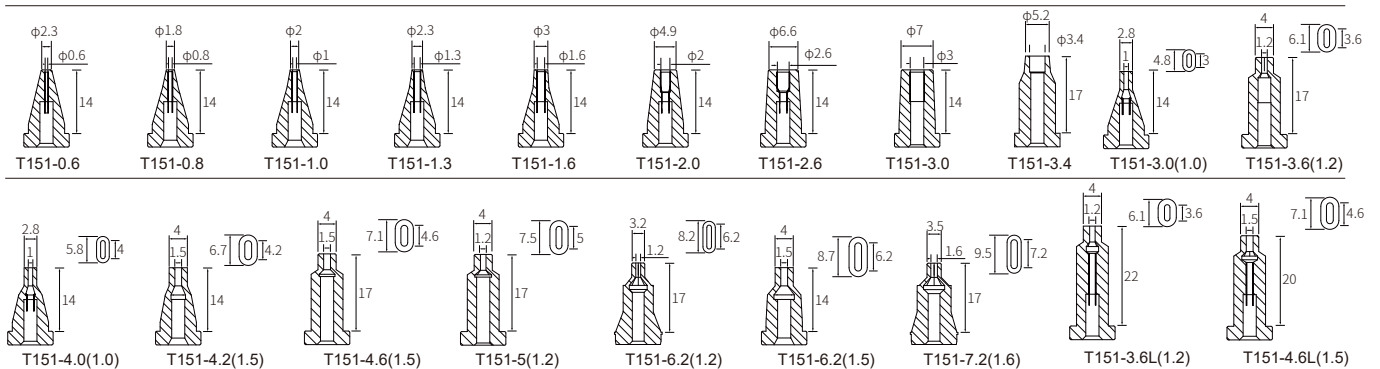

ST-1503D+/ST-9003D/ST-1303D/ST-3003D ESD SAFE

Heavy Duty Soldering Station

Features

- Principle of high-frequency eddy current heating.
- Three sets of quick temperature storage, switch freely.
- Adjustable intelligent sleep standby, effectively ensuring safety and extending product lifespan.
- One click infrared temperature calibration function, quickly calibrate the temperature of the product.

Specification

Model	ST-1503D+	ST-9003D	ST-1303D	ST-3003D
Voltage	AC 230V±10% 50Hz (110V±10% 60Hz)			
Power	150W	90W	150W	300W
Temperature Range	80°C~600°C	80°C~500°C		80°C~600°C
Heating Principle	High Frequency Eddy Current Heating			
Handle Model	SP-H150+	SP-H090	SP-G120	SP-H300
Handle Power	≥150W	≥90W	≥120W	≥300W
Heater	HS-3150H	HS-3090H	HS-3120	HS-3300H
Soldering Tips	T500 Series	T300 Series	T121 Series	T330 Series
communication Function	Support (RS485)			
IR Temperature Calibration	Support			
Tip-to-ground Resistance	≤2Ω			
Tip-to-ground Potential	≤2mV			
Dimension(Main Unit)	200X125X120mm			240X125X120mm
Weight(Main Unit)	≈3.72kg	≈3kg	≈3.3kg	≈2.3kg

Package List

Model	Packing List			
ST-1503D+	Main unit x1	Soldering iron handle x1		
ST-9003D	Power cord x1	Iron stand x1		
ST-1303D	User manual x1	Ground wire x1		
ST-3003D	Host x1	Soldering iron handle x1	Power cord x1	Certificate x1
	Iron stand x1	Ground wire x1	Hex wrenches x1	User manual x1



Linkage Function

Support collaboration with fume extractor.



RS485 communication interface connected



Can be used with ST-1090 temperature tester for one click temperature calibration.

Infrared Temperature Calibration

High Frequency Eddy Current Heating

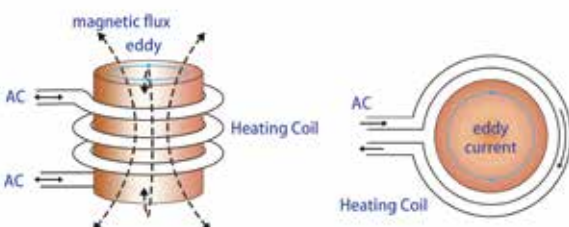

Communication Function

RS485 interface

Connect the computer and set various parameters through the upper computer software.



Remote process control

Replacement of Heating Components

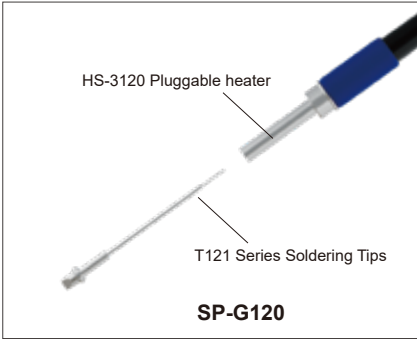
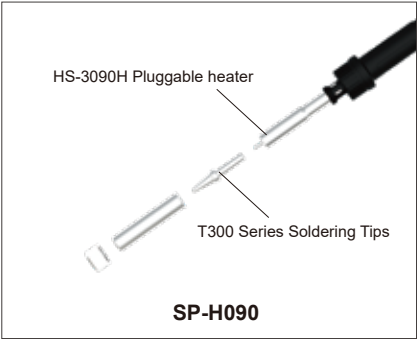

You can choose a soldering tip according to your needs, suitable for various soldering processes
(Bent tip soldering iron tip, suitable for soldering in narrow spaces)

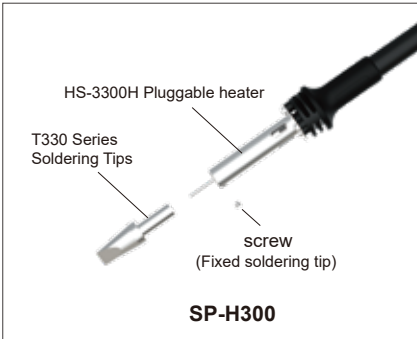
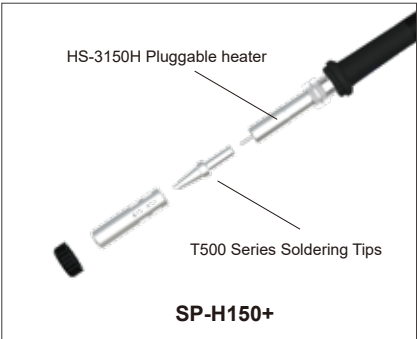

You can choose a soldering tip according to your needs to easily handle large solder joint processes
(Groove shaped soldering tip, sufficient soldering flux)











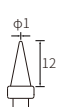
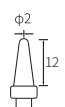

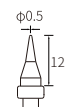

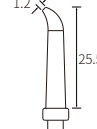
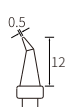

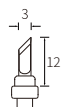

Tài liệu được tổng hợp bởi đội ngũ kỹ thuật của **NPOWER**
Bản quyền nội dung thuộc về **Atten**





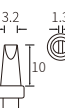

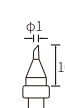
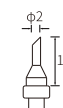
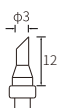
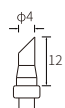

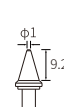
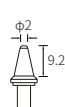

Powered by **NAVITECH** | www.navitech.co
www.npower.com.vn

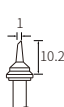
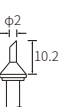
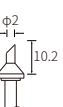
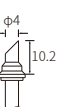
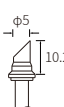
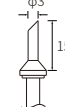
Optional Tips

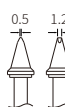

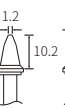

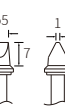
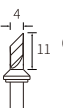

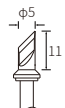

T300  (Applicable model: ST-9003D)

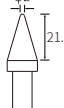
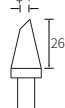
 T300-B	 T300-2B	 T300-LB	 T300-I	 T300-SI	 T300-LI	 T300-H	 T300-J	 T300-IS	 T300-0.5IS	 T300-K	 T300-SK
 T300-0.8D	 T300-1.2D	 T300-1.6D	 T300-2.4D	 T300-3.2D	 T300-4.2D	 T300-0.8C	 T300-1C	 T300-2C	 T300-3C	 T300-4C	



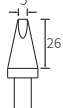
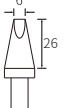
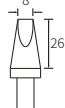

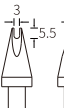
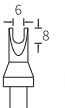
T121  (Applicable model: ST-1303D)

 T121-B	 T121-2B	 T121-LB	 T121-I	 T121-1C	 T121-2C	 T121-3C	 T121-4C	 T121-5C	 T121-3CF	 T121-0.8D	 T121-1.2D
 T121-1.6D	 T121-2.4D	 T121-3.2D	 T121-4.2D	 T121-5D	 T121-SK	 T121-LK	 T121-K				

T330  (Applicable model: ST-3003D)

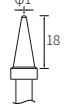
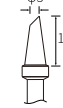
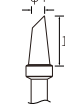
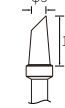
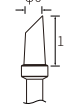
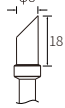
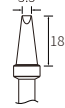
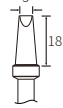
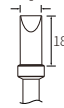
 T330-B	 T330-4C	 T330-6C	 T330-8C	 T330-10C	 T330-5D	 T330-6D	 T330-8D	 T330-10D	 T330-16D
 T330-6DU	 T330-10DU	 T330-K							

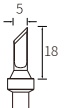
T500  (Applicable model: ST-1503D+)

 T500-B	 T500-3C	 T500-4C	 T500-5C	 T500-6C	 T500-8C	 T500-3.5D	 T500-5D	 T500-8D
 T500-SK	 T500-K	 T500-2.0SK	 T500-2.5SK					

ST-1509

Digital Soldering Station

Features

- 3 sets shortcut temperature to simplify operations.
- Using integrated soldering tips, rapid heating.
- Support temp lock, temp calibration function.
- Auto standby and sleep function, conserves energy and protect equipment



Specification

Model	ST-1509
Voltage	AC 230V±10% 50Hz (110V±10% 60Hz)
Power	150W
Temperature Range	80°C~480°C
Heating Principle	Resistance heating
Handle Model	Y950 / Y9130 / Y9150 / N9100
Heater	Integrated heater
Soldering Tips	T950 Series / T9130 Series / T9150 Series / T9100 Series
Tip-to-ground Resistance	≤2Ω
Tip-to-ground Potential	≤2mV
Dimension(Main Unit)	210 (L) x88 (W) x150 (H) mm
Weight(Main Unit)	≈3.26kg

Package list

Model	Package list
ST-1509	Main unit x1 x1 Soldering iron handle x1 Iron stand x1 Power cord x1 User manual x1 Certificate x1

Replacement of heating components

T950 Series integrated heater



Can quickly replace soldering tips during work



S-13



S-14

Silicone iron stand

Types of handle



Y950

50W mini soldering iron, suitable for small welding components.
(Using T950 series integrated soldering tip)



Y9130

130W middle size soldering iron, suitable for most welding components.
(Using T9130 series integrated soldering tip)



Y9150

150W soldering pen, suitable for soldering oversized pads and large workpieces.
(Using T9150 series integrated soldering tip)



N9100

100W electric tweezers, suitable for soldering and desoldering various SMD devices.
(Using T9100 series integrated electric tweezers)

Product accessories (Mini Pot)



S-1815SP-T9150

Product application:
 Molten solder
 Tinning wire ends
 Desoldering components
 on PCB tin plating



Optional Tips

T950

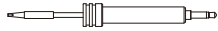

(Applicable model: ST-1509)

 T950-0.1IS	 T950-0.3IS	 T950-0.1SI	 T950-0.3SI	 T950-0.5I	 T950-1.2C	 T950-K	 T950-2.0SK	 T950-3.5SK	 T950-1.3D	 T950-2.2D	 T950-3.0D
----------------	----------------	----------------	----------------	---------------	---------------	------------	----------------	----------------	---------------	---------------	---------------

T9100



(Applicable model: ST-1509)

 T9100-0.2I	 T9100-0.5I	 T9100-1.0I	 T9100-1.3D	 T9100-2.2D	 T9100-0.7D	 T9100-0.7DS	 T9100-0301	 T9100-0601	 T9100-1001
 T9100-A0301	 T9100-A0601								

T9130



(Applicable model: ST-1509)

 T9130-C	 T9130-1.2C	 T9130-2.4C	 T9130-3.2C	 T9130-4.6C	 T9130-1.6D	 T9130-2.4D	 T9130-3.2D	 T9130-4.6D
 T9130-0.5I	 T9130-1.0I	 T9130-0.1SI	 T9130-0.2SI	 T9130-0.3SI	 T9130-SI	 T9130-0.1IS	 T9130-0.3IS	 T9130-0.5IS
 T9130-2.0CM	 T9130-3.0CM	 T9130-15D	 T9130-20D	 T9130-K	 T9130-SK	 T9130-2.0SK		

T9150



(Applicable model: ST-1509)

 T9150-B	 T9150-3C	 T9150-5C	 T9150-6.5C	 T9150-3.2D	 T9150-4.6D	 T9150-6.5D	 T9150-10D	 T9150-15.5D
 T9150-4.6D(B3*2.5)	 T9150-K	 T9150-1815SP						

ST-909

Digital Soldering Station

Features

- 3 sets shortcut temperature to simplify operations.
- Using integrated soldering tips, rapid heating.
- Support temp lock, temp calibration function.
- Smart standby function, conserves energy and protect equipment.



Specification

Model	ST-909
Voltage	AC 230V±10% 50Hz (110V±10% 60Hz)
Power	90W
Temperature range	200°C~500°C
Heating principle	Resistance heating
Handle Model	SP-990
Heater	Integrated heater
Soldering tips	T990 Series
Tip-to-ground resistance	≤2Ω
Tip-to-ground potential	≤2mV
Dimension(Main Unit)	175(L)x115(W)x95(H)mm
Weight(Main Unit)	≈1.71kg

Package List

Model	Package List
ST-909	Main unit x1 Soldering iron handle x1 Iron stand x1 Power cord x1 User manual x1 Certificate x1

Replacement Of Heating Components



Anti scald sleeve can be used to quickly replace the soldering tip

T990 Series Soldering Tips



Stably hold the handle

Iron Stand

Optional Tips

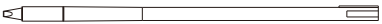
T990  (Applicable model: ST-909 ST-8902D)

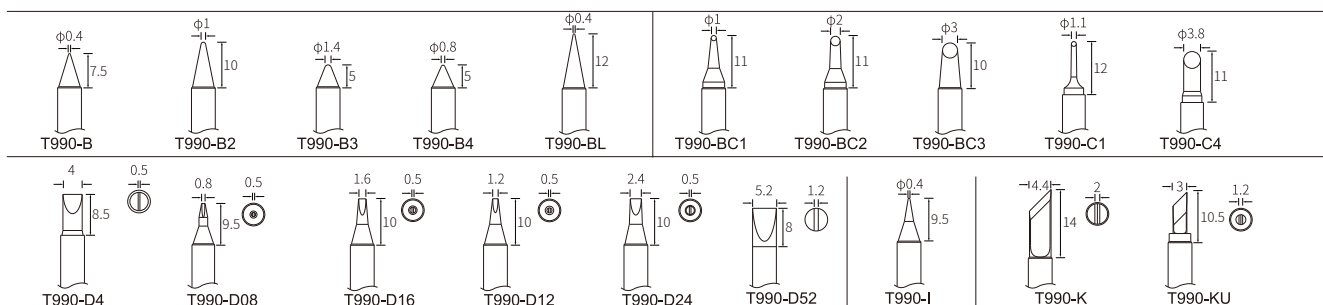

ST-60/ST-80

Digital Soldering Station

Features

- 3 sets shortcut temperature to simplify operations.
- Support temp lock, temp calibration function.
- Smart standby and shutdown function, conserves energy and protect equipment.

Specification

Model	ST-60	ST-80
Voltage	AC 230V±10% 50Hz (110V±10% 60Hz)	
Power	60W	80W
Temperature Range	150°C~480°C	
Heating Principle	Resistance heating	
Handle Model	SP-60	SP-80
Heater	Dual-core ceramic heater HS-3060A	Four-core ceramic heater HS-3080
Soldering Tips	T900 Series	
Tip-to-ground Resistance	≤2Ω	
Tip-to-ground Potential	≤2mV	
Dimension(Main Unit)	175(L)x115(W)x95(H)mm	
Weight(Main Unit)	≈1.28kg	≈1.71kg

Package List

Model	Package List
ST-60	Main unit x1 Soldering iron handle x1 Iron stand x1
ST-80	Power cord x1 User manual x1 Certificate x1



Replacement of Heating Components

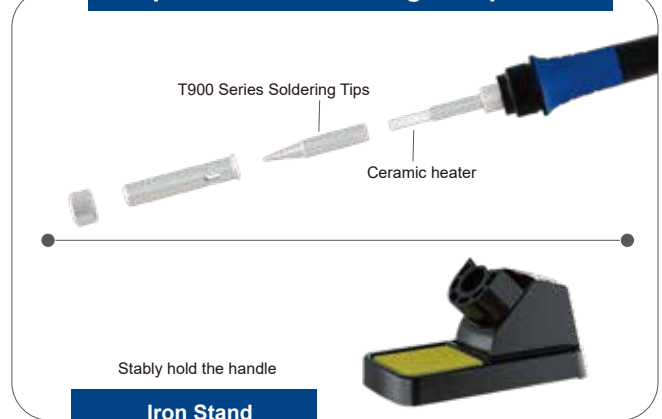









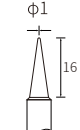



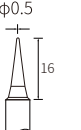

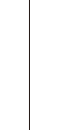
Optional Tips

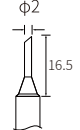
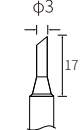
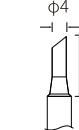
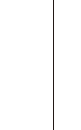
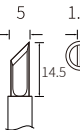
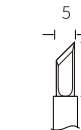
T900

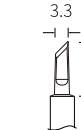
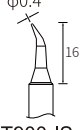

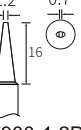
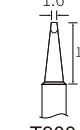
(Applicable model: ST-60 ST-80 ST-2090D AT-969 AT-989D ST-2065D)

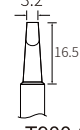
 T900-B	 T900-LB	 T900-SB	 T900-PB	 T900-I	 T900-0.2SI	 T900-SI	 T900-0.5C	 T900-0.8C	 T900-1C
 T900-2C	 T900-3C	 T900-4C	 T900-1.6K	 T900-K	 T900-2.0SK	 T900-SK	 T900-0.2IS	 T900-0.5IS	
 T900-IS	 T900-0.8D	 T900-1.2D	 T900-1.6D	 T900-2.4D	 T900-3.2D	 T900-2.0CM	 T900-3.0CM		

ST-100 (Upgraded version)

Digital Soldering Station

Features

- 3 sets shortcut temperature to simplify operations.
- Support temp lock, temp calibration function.
- Smart standby and shutdown function, conserves energy and protect equipment.



Specification

Model	ST-100
Voltage	AC 230V±10% 50Hz (110V±10% 60Hz)
Power	100W±10
Temperature Range	150°C~480°C
Heating Principle	Resistance heating
Handle Model	SP-100
Heater	100W Sliver alloy heater HS-3100
Soldering Tips	T800 Series
Tip-to-ground Resistance	≤2Ω
Tip-to-ground Potential	≤2mV
Dimension(Main Unit)	175(L)x115(W)x95(H)mm
Weight(Main Unit)	≈1.71kg

Package List

Model	Package list
ST-100	Main unit x1 Soldering iron handle x1 Iron stand x1 Power cord x1 User manual x1 Certificate x1

















Replacement of Heating Components



Iron Stand

Optional Tips

T800 (Applicable model: ST-100)

 T800-0.25I	 T800-0.5I	 T800-1.0I	 T800-1.4I	 T800-1.2C	 T800-2.4C	 T800-3.2C	 T800-4.6C	 T800-0.8D	 T800-1.6D	 T800-3.2D	 T800-4.6D
 T800-K	 T800-SK	 T800-2CM	 T800-3CM								

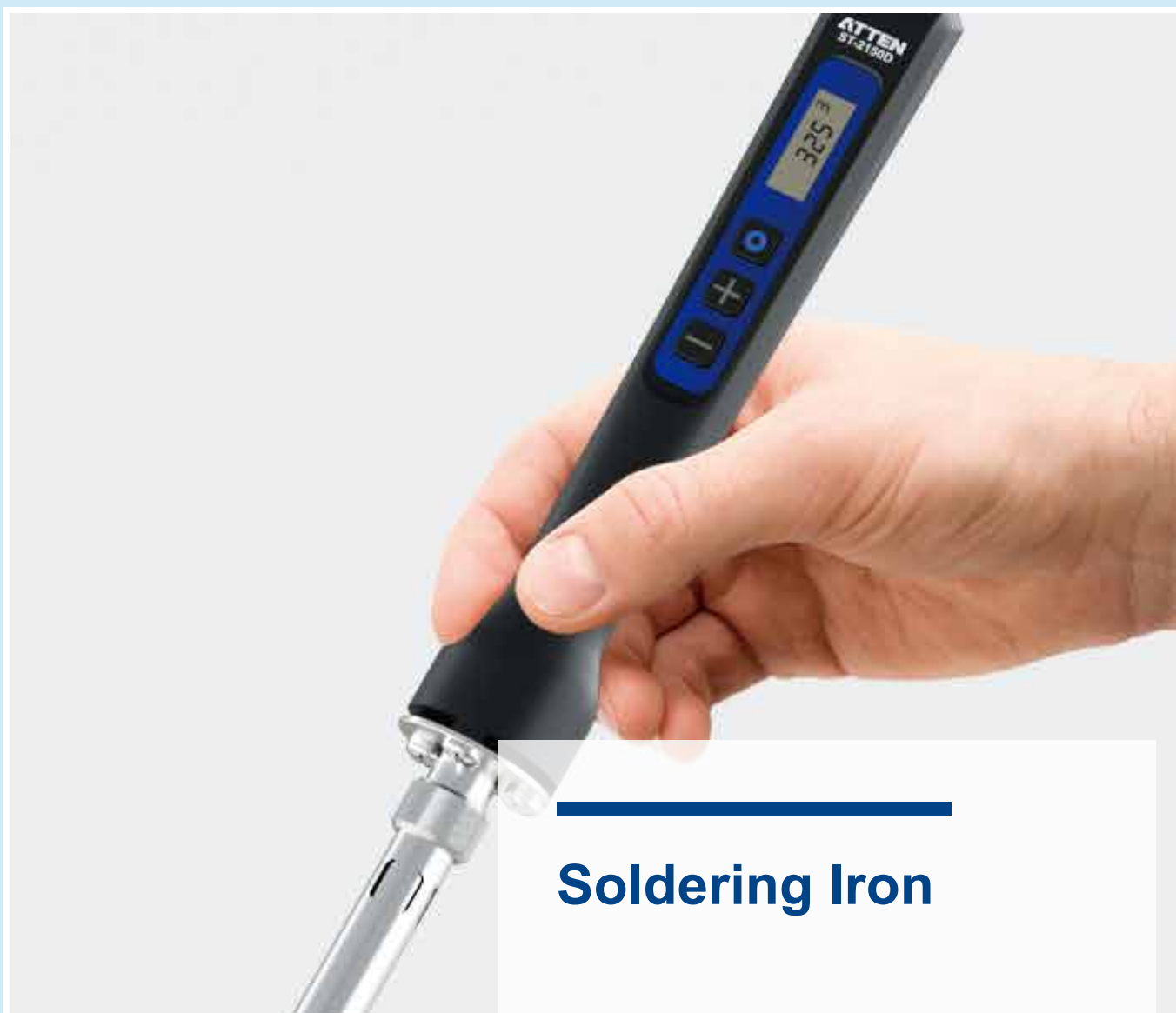

Soldering Iron



Tài liệu được tổng hợp bởi đội ngũ kỹ thuật của **NPOWER**
Bản quyền nội dung thuộc về **Atten**

Powered by **NAVITECH** | www.navitech.co
www.npower.com.vn

■ GT-2010+ USB Soldering Iron	21
■ ST-2065D,ST-2080D,ST-2150D Digital Soldering Iron	22

GT-2010+

USB Soldering Iron

Features

- 3 sets shortcut temperature to simplify operations.
- Using integrated soldering tips, rapid heating.
- USB standard interface of power bank or adapter supply it with electricity.
- Auto sleep function, conserves energy and protect equipment

Specification

Model	GT-2010+
Voltage	5V DC
Power	10W
Temperature Range	100°C~450°C
Heating Principle	Resistance Heating
Temperature Stability	±2°C (in still air, no load)
Temperature Offset Range	±50°C
Tip-to-ground Resistance	≤2Ω
Tip-to-ground Potential	≤2mV
Dimension	15.2 (L) x15.2 (W) x210 (H) mm
Weight	≈0.12kg

Package List

Model	Package List
GT-2010+	GT-2010+ Soldering iron x1 Manual x1



Replacement of Heating Components

Plug in replacement is convenient and fast.

T10 Series integrated heater



Metal soldering iron stand, sturdy and durable.

S-10 Iron Stand (Optional)

Optional Tips

T10

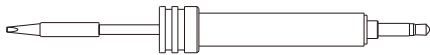

(Applicable model: GT-2010+)

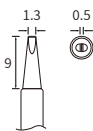

T10-1.3D

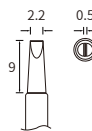

T10-2.2D

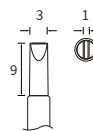

T10-3.0D



T10-1.2C



T10-0.5I

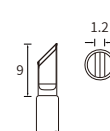

T10-K

ST-2065D/ST-2080D/ST-2150D

Soldering Iron

Features

- 9 sets shortcut temperature to simplify operations.
- Automatic sleep after 10 minutes inactivity.
- Automatic shut down after 20 minutes inactivity.

Specification

Model	ST-2065D	ST-2080D	ST-2150D
Voltage	AC 230V±10% 50Hz (110V±10% 60Hz)		
Power	65W	80W	150W
Temperature Range	80°C~480°C		
Heating Principle	Resistance heating		
Temperature Stability	±2°C (in still air, no load)		
Heater	Ceramic heater HS-2065D	Ceramic heater HS-2080	Ceramic heater HS-2150
Soldering Tips	T900 Series	T2080 Series	T2150 Series
Adjustment Method	Button		
Temperature Unit	°C/°F		
Display Method	LCD		
Dimension	27 (L) x27 (W) x230 (H) mm		
Weight	≈0.20kg		

Package List

Model	Package List
ST-2065D	Soldering Iron x1
ST-2080D	Manual x1
ST-2150D	Simple bracket x1



Replacement of Heating Components

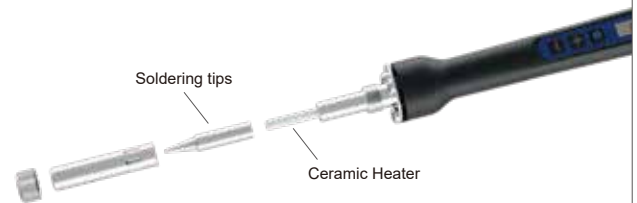

Metal iron stand, sturdy and durable

S-11 Iron Stand(Optional)







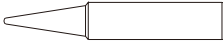

LCD display screen
Accurate and flexible temperature control,
efficient operation.

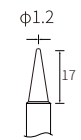
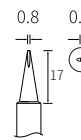
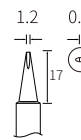
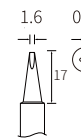
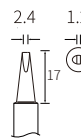
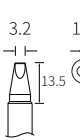

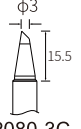

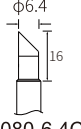
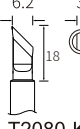

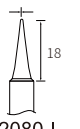
Optional Tips

T2080  (Applicable model: ST-2080D)

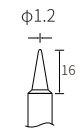
 φ1.2 17 T2080-B	 0.8 0.4 17 T2080-0.8D	 1.2 0.6 17 T2080-1.2D	 1.6 0.6 17 T2080-1.6D	 2.4 1.2 17 T2080-2.4D	 3.2 1.2 13.5 T2080-3.2D	 4.6 1.6 14 T2080-4.6D
 6.2 2 13.5 T2080-6.5D	 φ3 15.5 T2080-3C	 φ5 16 T2080-5C	 φ6.4 16 T2080-6.4C	 6.2 3 18 T2080-K	 3.3 2 18 T2080-SK	 φ0.5 18 T2080-I

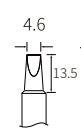
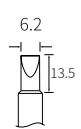
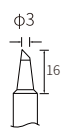
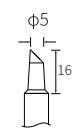
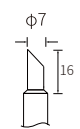
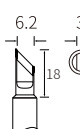
T2150  (Applicable model: ST-2150D)

 φ1.2 16 T2150-B	 3.2 1.2 14 T2150-3.2D	 4.6 1.6 13.5 T2150-4.6D	 6.2 2 13.5 T2150-6.5D	 φ3 16 T2150-3C	 φ5 16 T2150-5C	 φ7 16 T2150-7C
 6.2 3 18 T2150-K	 φ0.5 18.4 T2150-I					

Note: T900 series soldering tip details in page 18.



Automatic Equipment



Tài liệu được tổng hợp bởi đội ngũ kỹ thuật của **NPOWER**
Bản quyền nội dung thuộc về **Atten**

Powered by **NAVITECH** | www.navitech.co
www.npower.com.vn

■ ZT-664-4030 Four-axis Soldering Robot	25
■ ZT-661-200H Single Axis Semi-Automatic Soldering Robot	27
■ ZT-660-150G Auto-Feed Soldering Station	29

ZT-664-4030

Four-axis Automatic Soldering Robot

Features

- The amount of tin sent can be adjusted according to the size of the solder joint of the object being soldered.
- Equipped with reflow function to reduce solder waste.
- Fast and stable heating, high work efficiency.

Specification

Model	ZT-664-4030
Voltage	AC 220-240V~50/60Hz
Power	450W
Heating Power	300W
Temperature Range	80 C~500 C
The Handle Model	ZT-Y300
The Heating Model	T472 Series
Tip-to-ground Resistance	
Handle wire length	300cm
Equipment Stroke	X:320mm, Y: 400mm, Z:50mm, R: ±360°
Maximum Shaft Speed	X、Y: 720mm/sec, Z: 720mm/sec, R: 600°/sec
Repeat Positioning Accuracy	X、Y、Z: ±0.02mm, R: ±0.05°
Resolution	X、Y、Z: 0.02mm, R: 0.05°
Tin Feeding/Tin Breaking System	Independent Drive
Maximum Tin Feeding Speed	50mm/sec
Tin Feeding Accuracy	Tolerances ≤5%
Allowable Tin Wire Diameter	Φ (0.5-1.5) mm
Production Formula Capacity	85 formulas Each formula contains 200 functional points. (If there are several points in one copy or one array, only one function point is counted) (Note: The number of recipes is saved in HMI)
Soldering method setting	Soldering Mode Parameters Include: Temperature setting, tin feeding speed, pre-tin feeding, preheating time, two-stage tin feeding, two-stage delay, three-stage tin feeding, three-stage delay. Soldering Auxiliary Function: Oblique insertion feeding, up and down/left and right tin shaking.
Soldering Tip Cleaning	Tin feeding + air blowing method to remove tin slag on the soldering tip
Air Pressure Requirement	(0.4—0.8) MPa
Control Mode	PLC+HM (17.1 inch)
Dimension(Main Unit)	750(L)x750(W)x850(H)mm
Weight(Main Unit)	66.8KG

Package List

Model	Package List
ZT-661-4030	<ul style="list-style-type: none"> • Main unit x1 • Handheld teaching pendant x1 • Gas source components x1 • Power cord x2 • Hexagonal screwdriver set x1 • Certificate x1 • One handed open-end wrench x2 • User manual x1



Tip Cleaning Function

After moving the soldering iron to the cleaning position and starting to heat up, perform air blowing cleaning.

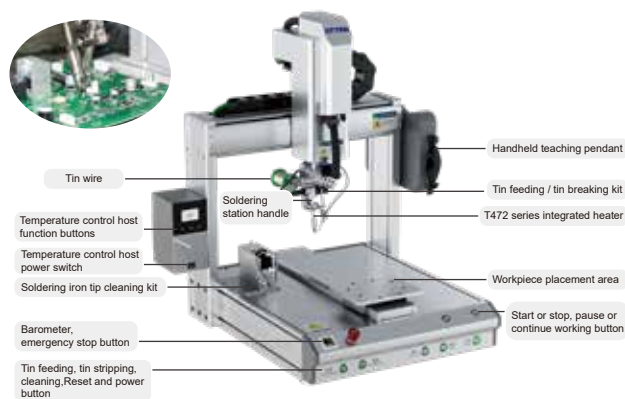
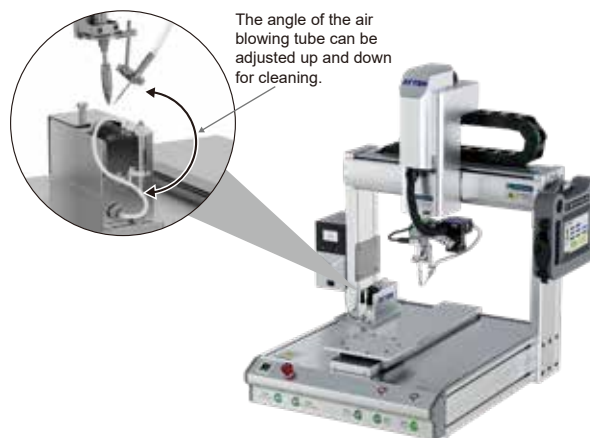

Exterior Component Structure

Varing Soldering Method

Solder Feeding Device



Solder Breaking Device (Optional)

Optional solder breaking device to effectively prevent solder balls and flux from scattering.

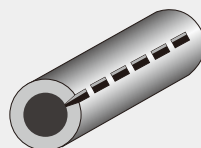

Solder breaking component

Solder breaking gear set

- K-65TW 0.5mm
- K-65TW 0.8mm
- K-45TW 1.0/1.2mm
- K-45TW 1.5mm

Solder cutting knife

- K-65TW 0.5/0.8mm
- K-45TW 1.0/1.2/1.5mm

Solder Feed Tube

Model	Specifications	Illustration
ZP-D05-25	Solder wire diameter 0.5-0.6mm	
ZP-D08-25	Solder wire diameter 0.7-0.8mm	
ZP-D10-25	Solder wire diameter 0.9-1.0mm	
ZP-D12-25	Solder wire diameter 1.1-1.2mm	
ZP-D15-25	Solder wire diameter 1.3-1.5mm	

Handle



Optional Tips

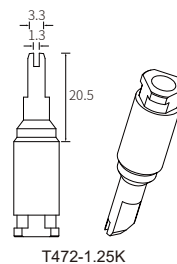
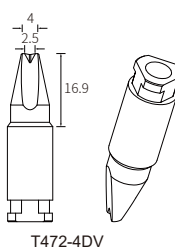
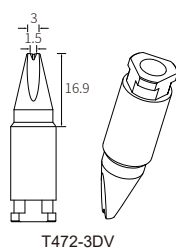
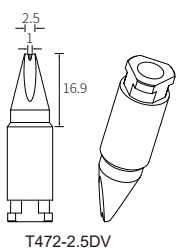
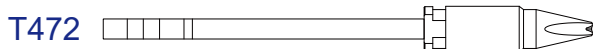

ZT-661-200H ESD SAFE

Single Axis Semi-Automatic Soldering Robot

Features

- MCU touch screen control, easy to debug and operate.
- Air pump for blowing and cleaning, high welding efficiency, saving time and labor costs.
- Just need to replace the fixture, can solder different products.
- Equipped with foot switch control mode and automatic control mode.

Specification

Model	ZT-661-200H
Voltage	AC 220-240V~50/60Hz (AC 110-120V~60Hz)
Power	250W(±10%)
Heating Principle	High Frequency Eddy Current Heating
Temperature Range	80°C~500°C
Temperature Compensation	±50°C
Quick Parameters	Supports customization of 10 sets of quick parameters
Solder Breaking Function	Optional(standad without broken tin)
The Handle Type	ZP-200HG
The Handle Power	≥200W
Heater	HS-200H
Soldering Tip	T511G Series
Tip-to-ground Resistance	≤2Ω
Tip-to-ground Potential	≤2mV
Work Conditions	Temperature: 0°C~40°C Humidity: <85%RH
Dimension(Main Unit)	320 (L) x350 (W) x285 (H) mm
Weight(Main Unit)	≈13.2kg

Package List

Model	Package List
ZT-661-200H	<ul style="list-style-type: none"> • Main unit x1 • 0.8m tin removal plastic pipe x1 • Solder wire rack x1 • Pedal x1 • Power cord x1 • Grounding wire x1 • User manual x1 • Certificate x1 • One handed open-end wrench x1 • Hexagonal screwdriver set x1



Communication Function

RS485 interface

Connect the computer and set various parameters through the upper computer software.



Support collaboration with Atten fume extractor.



Linkage Function

Varing Soldering Method

Solder Feeding Device



Solder Breaking Device (Optional)

Optional solder breaking device to effectively prevent solder balls and flux from scattering.

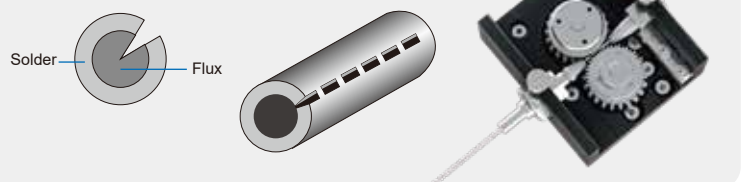

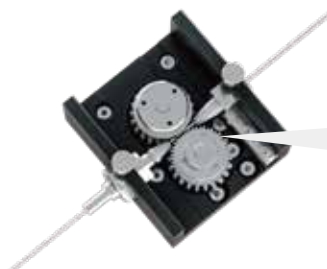

Solder breaking component

Solder breaking gear set

- K-65TW 0.5mm
- K-65TW 0.8mm
- K-45TW 1.0/1.2mm
- K-45TW 1.5mm

Solder cutting knife

- K-65TW 0.5/0.8mm
- K-45TW 1.0/1.2/1.5mm

Pedal Mode



Can be used in conjunction with fixtures for automatic soldering, reducing the unevenness of manual soldering and improving the stability of soldering quality. It can be connected to an external foot switch for easy operation.

Solder Feed Tube

Model	Specifications	Illustration
ZP-D06	Solder wire diameter 0.5-0.6mm	ϕ 0.5-0.6mm
ZP-D08	Solder wire diameter 0.7-0.8mm	ϕ 0.7-0.8mm
ZP-D10	Solder wire diameter 0.9-1.0mm	ϕ 0.9-1.0mm
ZP-D12	Solder wire diameter 1.1-1.2mm	ϕ 1.1-1.2mm
ZP-D16	Solder wire diameter 1.3-1.5mm	ϕ 1.3-1.5mm

Handle



Optional Tips

T511G



 T511G-U(5.0*2.0)	 T511G-U(6.0*2.0)	 T511G-U(7.0*2.0)	 T511G-U(9.5*2.5)	 T511G-U(10*2.5)	 T511G-U(11*2.5)	 T511G-U(15*2.5)
 T511G-U(8-2-3)	 T511G-U(10-2.5-5.1)	 T511G-U(13-2.5)	 T511G-U(20-2.5)	 T511G-U(9.5-2.5-4.5)	 T511G-U(8.0-2.0)	 T511G-3.5CV

ZT-660-150G ESD SAFE

Auto-Feed Soldering Station

Features

- Automatic solder dispensing system, one handed operation, simple and easy soldering, improving work efficiency.
- Set the solder feeding speed and length.
- Reduce the scattering and solder balls generated by lead-free solder during high-temperature soldering.

Specification

Model	ZT-660-150G
Voltage	AC 220-240V~50/60Hz (AC 110-120V~60Hz)
Power	180W(±10%)
Solder Breaking Function	Optional(standad without broken tin)
Temperature Range	80°C~500°C
Temperature Compensation	±50°C
Quick Parameters	Supports customization of 10 sets of quick parameters
Solder Breaking Function	Optional(standad without broken tin)
The Handle Type	ZP-155G
The Handle Power	≥150W
Heater	T155 Series
Tip-to-ground Resistance	≤2Ω
Tip-to-ground Potential	≤2mV
Work Conditions	Temperature: 0°C~40°C Humidity: <85%RH
Dimension(Main Unit)	275x180x117mm
Weight(Main Unit)	≈4.1kg

Package List

Model	Package list	
ZT-660-200H	Main unit x1	Soldering Iron x1
	Soldering Iron Stand x1	Pedal x1
	Solder Wire Stand x1	Stand Cable x1
	Grounding wire x1	Power cord x1
	User manual x1	Certificate x1

Heating Test

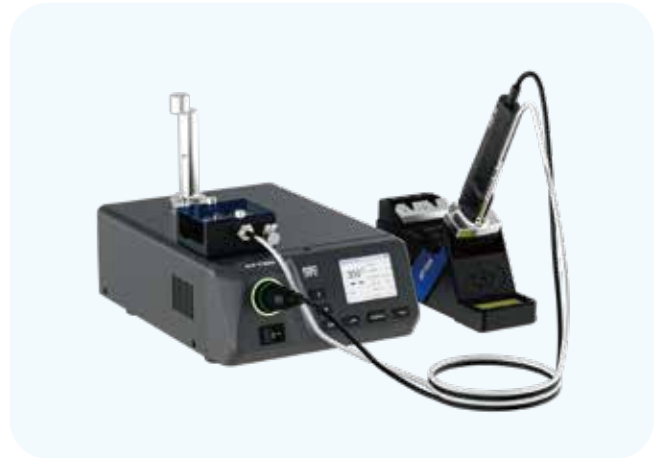
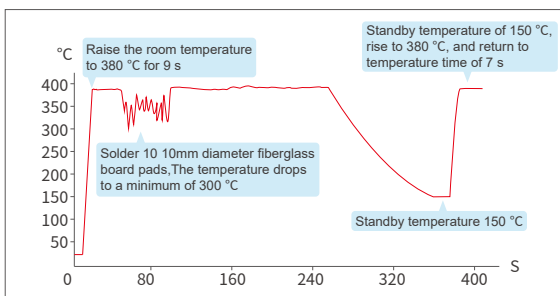

Replacement of Heating Components

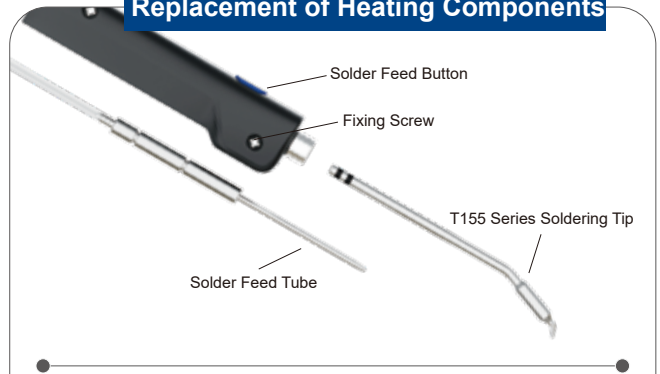

Connect the cable to the soldering iron holder and use the standby function. Pick up the handle to work. Place the handle into the soldering iron holder to standby mode.

Standby Function

Multi Functional Soldering Iron Holder

Stably grip the handle for safe installation and disassembly of the soldering tip.



The Welding Method Can be Freely Changed

Manual Soldering

Soldering without holding the solder wire manually, simplifying the process.



Fixed Holder (Optional)

Operate the product directly with both hands, and the product can directly touch the soldering iron tip to improve work efficiency.



Solder Feeding Device



Solder Breaking Device (Optional)

Optional solder breaking device to effectively prevent solder balls and flux from scattering.

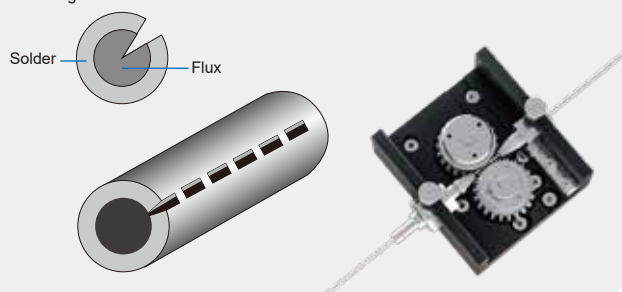

Pedal

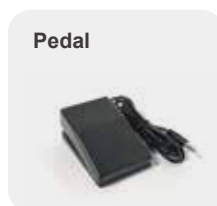

Solder Breaking Component

Solder breaking gear set

- K-65TW 0.5mm
- K-65TW 0.8mm
- K-45TW 1.0/1.2mm
- K-45TW 1.5mm

Solder cutting knife

- K-65TW 0.5/0.8mm
- K-45TW 1.0/1.2/1.5mm

Solder Feed Tube

Model	Specifications	Illustration
ZP-D06M	Solder wire diameter 0.5-0.6mm	$\phi 0.5-0.6\text{mm}$
ZP-D08M	Solder wire diameter 0.7-0.8mm	$\phi 0.7-0.8\text{mm}$
ZP-D10M	Solder wire diameter 0.9-1.0mm	$\phi 0.9-1.0\text{mm}$
ZP-D12M	Solder wire diameter 1.1-1.2mm	$\phi 1.1-1.2\text{mm}$
ZP-D16M	Solder wire diameter 1.3-1.5mm	$\phi 1.3-1.5\text{mm}$

Optional Tips

T155 (Applicable model: ZT-660-150G)

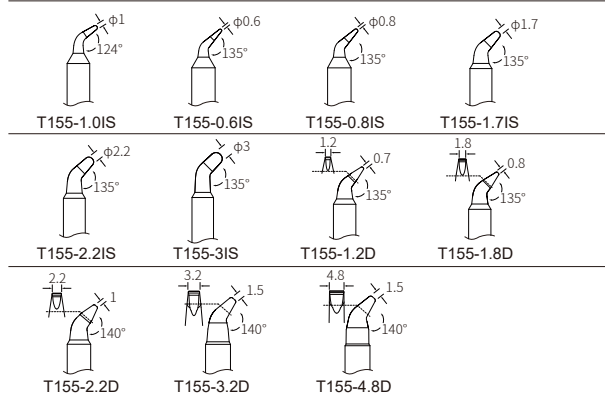



Hot Air Station



Tài liệu được tổng hợp bởi đội ngũ kỹ thuật của **NPOWER**
Bản quyền nội dung thuộc về **Atten**

Powered by **NAVITECH** | www.navitech.co
www.npower.com.vn

■ GT-1028,GT-8100A Intelligent Hot Air Rework Station	32
■ ST-862D Hot Air Station	33
■ ST-8800D Hot Air Station	34
■ ST-2308DX Heat Gun	36

GT-1028/GT-8100A

Intelligent Hot Air Station

Features

- 3 sets shortcut temperature to simplify operations.
- Built-in brushless fan, long use life and low noise.
- Temperature curve setting function.
- Infrared temperature calibration function.
- Equipped with a vacuum suction pen, components can be extracted after desoldering.

Specification

Model	GT-1028	GT-8100A
Voltage	AC 230V±10% 50Hz (110V±10% 60Hz)	
Power	1330W (220-240V~) / 1000W (110-120V~)	
Temperature Range	100°C~500°C	
Air Flow	120L/min(Max)	
Timing Time	10-900s	
Vacuum Pen	GT-B001(GT-8102A)	No
Nitrogen Interface	No	Yes
IoT Function	RS485	
Handle Model	SP-202D	
Pedal	Yes(Optional)	
Dimension(Main Unit)	230(L)x142(W)x145(H)mm	
Weight(Main Unit)	≈4kg	≈3.5kg

Package List

Model	Package List
GT-1028	Main unit x1 Power cord x1 Hot air gun handle x1 Hot air gun nozzle x3 Hot air gun holder x1 USB cable (A to B) x1 Vacuum pen (included tool box) x1 Bent suction nozzle x2 Straight suction nozzle x2 4.5mm suction disc x3 6.5mm suction disc x3 9.5mm suction disc x3 13mm suction disc x3 User manual x1 Certificate x1
GT-8100A	Main unit x1 Power cord x1 Hot air gun handle x1 Hot air gun nozzle x3 Hot air gun holder x1 USB cable (A to B) x1 User manual x1 Certificate x1

Linkage Function

Support collaboration with ATTEN fume extractor



RS485 communication interface connected



Replacement of Heating Components

Quick replacement of plug-in heating element

Pluggable heater HR-2102B

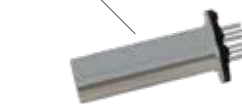

850 series nozzle details in page 35.

850 Series Nozzle (Optional)

Communication Function

RS485 interface

Connect the computer, set various parameters through the upper computer software, and display the temperature curve.

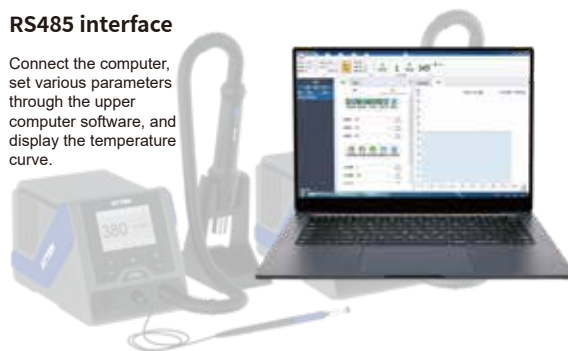

ST-862D

Hot Air Station

Features

- 3 sets shortcut temperature to simplify operations.
- Temperature locking, timed work function.
- Strong air volume with brushless fan.
- Easy to replace with pluggable heater.
- Convertible with straight air and spiral air.
- Auto-sleep function.



A2600 Nozzle converter



A-2605



A-2664



B-2608



B-2610



Specification

Model	ST-862D
Voltage	AC 230V±10% 50Hz (110V±10% 60Hz)
Power	1000W
Temperature Range	100°C~480°C
Air Flow	20~120L/min
Setting Range of Air Volume	1%~99%
Temperature Compensation	±50°C
Handle Model	SP-102B
Dimension(Main Unit)	208(L)x175(W)x150(H)mm
Weight(Main Unit)	≈2.86kg

Package List

Model	Package List
ST-862D	Main unit x1 Hot air gun x1 Manual x1 Nozzles x4 Hot air gun holder x1 Power cord x1 Ground wire x1 Nozzle converter x1 Certificate x1

Replacement of Heating Components

Quick replacement of plug-in heating element

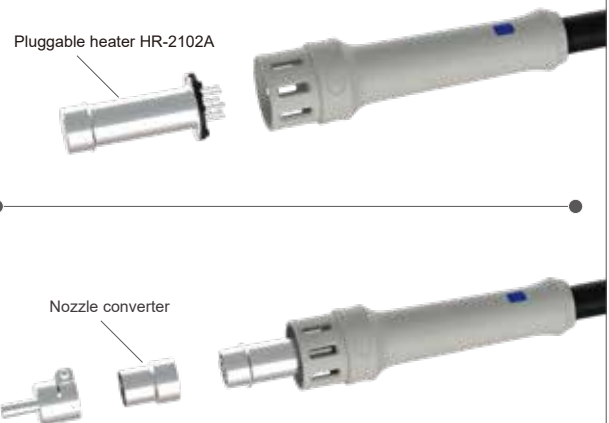

Can be used with all 850 series nozzles in conjunction with the standard A2600 adapter.
850 series nozzle details in page 35.

Nozzle Converter

Optional Nozzles (Applicable model: ST-862D)

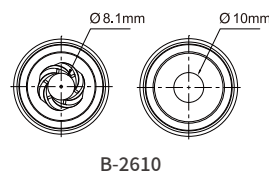
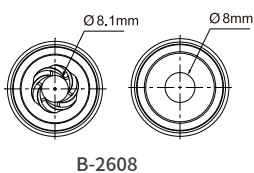
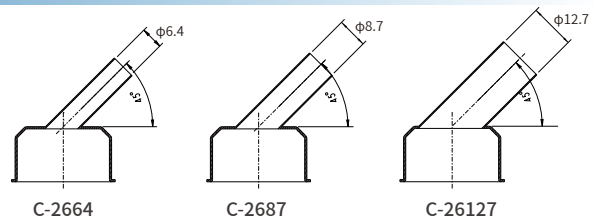
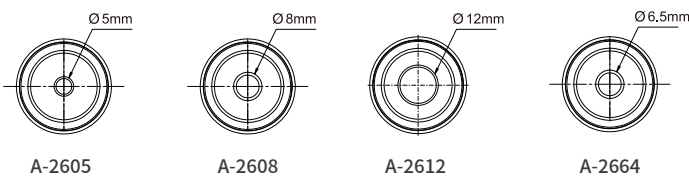

ST-8800D

Hot Air Station

Features

- 3 set shortcut air volume/temperature to simplify operations.
- Support temp lock, temp calibration.
- Auto standby and sleep function, conserves energy and protect equipment.
- Password-protected function to preserve settings.
- Cooling automatic function(standby), effectively protects the life span of heating core and handle.

Specification

Model	ST-8800D
Voltage	AC 230V±10% 50Hz (110V±10% 60Hz)
Power	800W
Temperature Range	100°C~500°C
Air Flow	30~120L/min
Setting Range of Air Volume	10%~100%
Temperature Compensation	±50°C
Handle Model	AP-800B
Dimension(Main Unit)	167(L)x142(W)x148(H)mm
Weight(Main Unit)	≈1.22kg

Package List

Model	Package List
ST-8800D	Main unit x1 Hot air gun x1 Manual x1 Nozzles x4 Hot air gun holder x1 Power cord x1 Ground wire x1 Certificate x1



Replacement of heating components

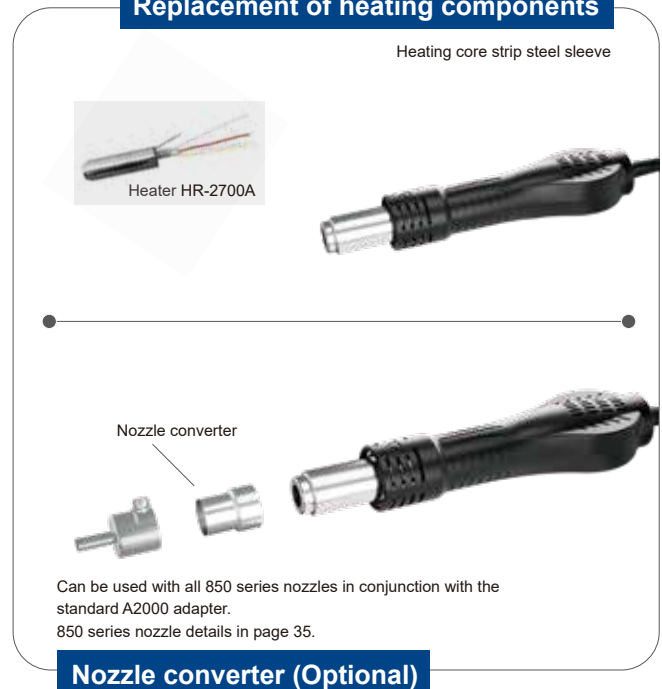

Nozzle converter (Optional)

Optional Nozzles (858 series) (Applicable model: ST-8800D ST-8802)

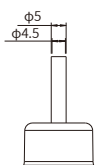

A-2101

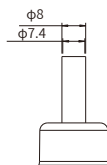

A-2102

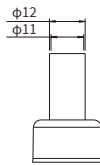

A-2103

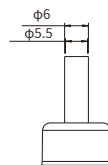

A-2104

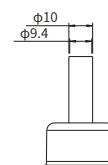

A-2105

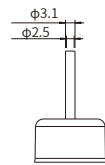

A-2131

Optional Nozzles (850 series) (Applicable model: GT-1028 GT-8100A ST-8902D MS-900)

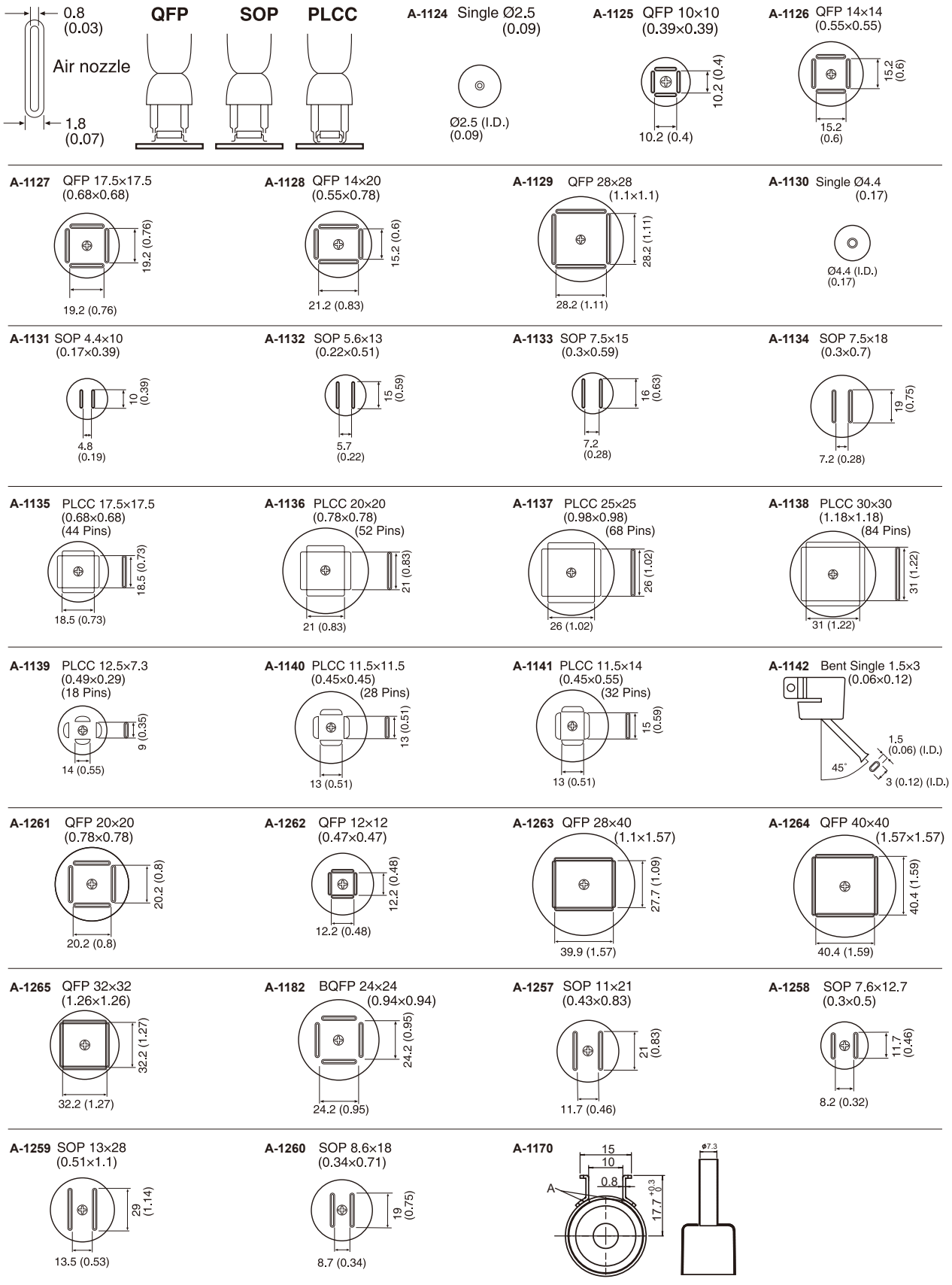

ST-2308DX

Heat Gun

Features

- 6 sets of quick temperature, can be quickly stored and called.
- Brushless fan, long service life.
- Comfortable grip, effective insulation, avoiding accidental burns.

Specification

Model	ST-2308DX
Voltage	AC 230V±10% 50Hz (110V±10% 60Hz)
Power	2300W
Temperature Range	50~650°C
Air Flow	200~500L/min
Remarks	LCD, Adjustable Temp, Brushless fan
Dimension	290x82x210mm
Weight	≈1.13kg

Package list

Model	Package List		
ST-2308DX	heating gun x1	Nozzle x1	User manual x1



Heat Gun Nozzles



T8230-23



T8230-15



T8230-85



T8230-67



T8230-43

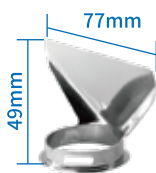

T8230-49



T8230-68



T8230-20

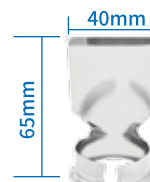

T8230-40

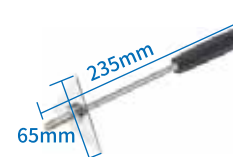

T8230-65

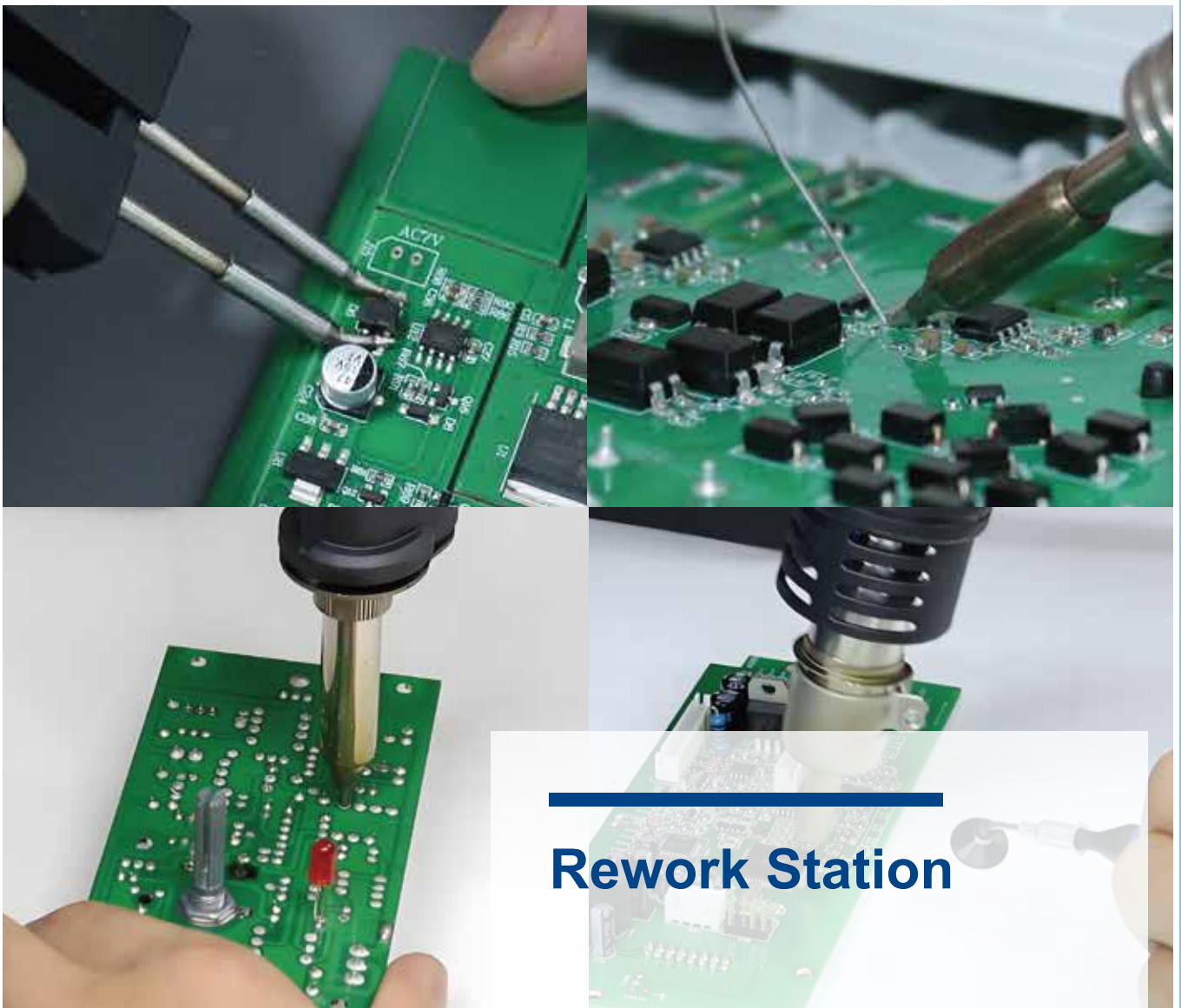

Rework Station



Tài liệu được tổng hợp bởi đội ngũ kỹ thuật của **NPOWER**
Bản quyền nội dung thuộc về **Atten**

Powered by **NAVITECH** | www.navitech.co
www.npower.com.vn

■ MS-900 4 In 1 Intelligent Rework Station	38
■ MS-500 3 In 1 Rework Station	40
■ ST-8902D 2 In 1 Rework Station	41
■ ST-8802 2 In 1 Rework Station	42

MS-900

4 In 1 Rework Station

Features

- 4 in 1 intelligent rework station with LCD display.
- High accuracy MCU control is employed to synchronously detect 3 tool channels that can be used independently and synchronously without mutual interference.
- Built-in vacuum generator.
- Support doing multiple desoldering tasks simultaneously.
- Automatically identify all kinds of soldering tools and load corresponding parameters.
- Adjust the temperature by software automatically, more accurate and convenient.
- Equipped with a vacuum suction pen, components can be extracted after desoldering.
- Auto standby and sleep function, conserves energy and protects equipment.
- Password-protected function to preserve settings.
- Built-in RS-232 communication interface, support computer control.



Replacement of Heating Components

Quick replacement of plug-in heating element

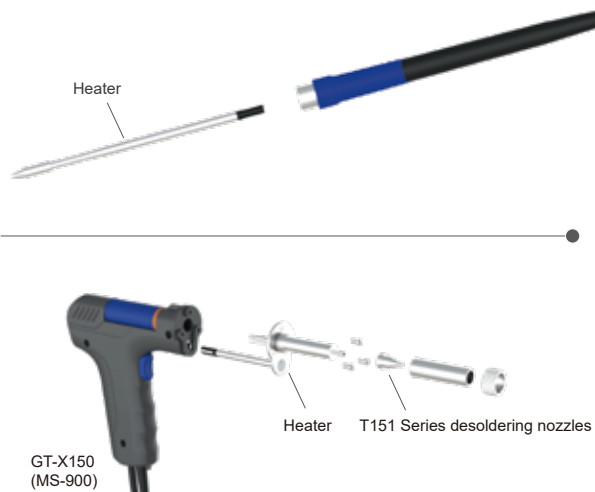

150W tin suction gun, ultra-high power, fast heating

Tin Removal Tool

Communication Function



Remote process control

Specification

Model	MS-900			
Voltage	AC 230V±10% 50Hz (110V±10% 60Hz)			
Total Power	900W			
Name	Hot Air Station	Soldering Station	Desoldering Station	Electronic Tweezer
Power	Heater 550W, Air pump 25W	130W	Heater 150W, Vacuum pump 15W	100W
Handle	AP-552B	GT-Y130	GT-X150(MS-900), GT-B001	GT-N100
Temperature Range	150°C~500°C	150°C~500°C	300°C~500°C	150°C~500°C
Standby	Room temperature	200°C	300°C	200°C
Standby Time	The handle automatically sleeps when placed on the bracket (Sleep time cannot be set)	1~120 minutes (0 i.e. standby deactivated)	1~120 minutes (0 i.e. standby deactivated)	1~120 minutes (0 i.e. standby deactivated)
Air Flow	23L/Min			
Tip-to-ground Resistance	≤2Ω			
Tip-to-ground Potential	≤2mV			
Dimension(Main Unit)	310(L)x309(W)x146(H)mm			
Weight(Main Unit)	≈8.27kg			

Package List

Model	Package List		
MS-900	Main unit x1	Blow-dryer bracket x1	Desoldering gun O-ring 6x1.5 x2
	Hot air gun x1	Screw x2	Desoldering gun O-ring x2
	Soldering iron stand x2	Suction disk x11	Desoldering tube liner x1
	Soldering pen x1	Suction nozzle x3	Filter cotton x10
	Electric tweezers x1	Rubber washer x2	Dust-absorbing sponge x10
	Desoldering gun x1	Desoldering nozzle x3	Spring pin (cleaning pin) x1
	Suction pen x1	Nozzle x4	Anti-ironing mat x1
	Power cord x1	Desoldering gun front plug x2	User Manual x1

Types of Handle



GT-Y050

50W mini soldering iron, suitable for small welding components.
(Using T50 series integrated soldering tip)



GT-Y130

130W middle size soldering iron, suitable for most welding components.
(Using T130 series integrated soldering tip)



GT-Y150

150W soldering pen, suitable for soldering oversized pads and large workpieces.
(Using T150 series integrated soldering tip)



GT-N100

100W electric tweezers, suitable for soldering and desoldering various SMD devices.
(Using T100 series integrated electric tweezers)

Vacuum Pen GT-B001 (MS-900)



Straight Suction Needle

Suitable for suction in unimpeded space.



Bent Suction Needle

Suitable for suction in limited space.



Anti static suction cup is suitable for current sensitive components and can be disassembled and pasted with materials such as IC/LED beads/resistors/chips

Metal Iron Stand



During use, the welding nozzle can be quickly disassembled



S-01



S-04

T50 T130 T150 T100 T151 details in page 05. 850 series nozzle details in page 35.

MS-500

3 In 1 Rework Station

Features

- Three in one welding table, hot air table, and power supply, suitable for various maintenance or repair processes

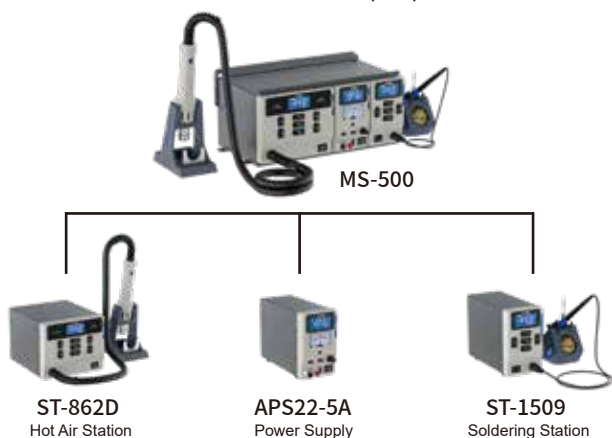

Specification

Suit Model	MS-500		
Voltage	AC 230V±10% 50Hz (110V±10% 60Hz)		
Host Model	ST-862D	ST-1509	APS22-5A
Power	1000W	150W	125W
Temperature Range	100~480°C	80~480°C	Ripple and noise CV≤0.5mVrms
Air Flow	20~120L/min		Protection function OCP(support automatically recovery)/OHP
The Handle Type	SP-102B	Y950	USB interface Fixed 5V output(±5%), maximum 2.1A output(overcurrent protection, stop outputting)
Haeter	HR-2102A	T950-0.11S	Heat-dissipating method Smart fan control
Tip-to-ground Resistance		≤2Ω	
Tip-to-ground Potential		≤2mV	
Dimension	220(L)x390(W)x170(H)mm		
Weight	≈11.56kg		

APS22-5A Power Supply

- MCU-Digital control, series adjustment mode control, low ripple, low noise, and high stability.
- The double-type head design is more suitable for the use of communication equipment products.
- Fast dynamic load response speed, optimized processing for communication equipment.
- The product is designed with cut-off self-recovery protection function and over-temperature protection function.
- Independent USB interface, providing 3A current output capability, with over-current and short-circuit protection support QC quick charge agreement.
- With output adjustment lock function, alarm prompt function, which can effectively prevent wrong operation.



Package List

Model	Package List
MS-500	ST-862D set APS22-5A set ST-1509 set One set of sheet metal frame



One machine with multiple uses, can be connected to different handle operation combinations. For example: Y9150 150W soldering pen handle, Y9130 130W soldering pen handle, Y950 50W soldering pen handle N9100 100W tweezers with multiple soldering iron tips to choose from, Capable of handling various welding tasks.

ST-1509 details in page 13. ST-862D details in page 27.

ST-8902D

2 In 1 Rework Station

Features

- Provide 3 sets shortcut temperature to avoid frequent settings.
- Use brushless fan, and the air volume is soft and adjustable.
- Designed with intelligent standby and automatic sleep functions.
- Temperature lock function, ensure constant temperature work.
- Software temperature compensation function, more accurate and convenient.

Specification

Model	ST-8902D	
Voltage	AC 230V±10% 50Hz (110V±10% 60Hz)	
Name	Soldering station	Hot air station
Power	90W	1300W
Temperature Range	200°C~500°C	100°C~500°C
Temperature Stability	±2°C	±5°C
Air Flow		20~120L/min
The Handle Type	SP-990	SP-202E
Dimension(Main Unit)	200(L)x170(W)x150(H)mm	
Weight(Main Unit)	≈4.8kg	

Package List

Model	Package List		
ST-8902D	Main unit x1	AC cord x1	Manual x1
	Gun holder x1	Ground wire x1	Iron stand x1
	Hot air gun x1	Iron handle x1	Nozzles x3
	Certificate x1		

The left side of the host is the hot air table operation area, and the right side is the welding table operation area



Replacement of heating components



Quick replacement of plug-in heating element

Anti scald sleeve can be used to quickly replace the soldering tip

T990 Series Integrated Heater

HR-2102B Heater



850 series nozzle

The handle is slim, lightweight, easy to grip, and easy to weld

850 series nozzle details in page 35. T990 integrated heater details in page 17.

ST-8802

2 In 1 Rework Station

Features

- Built-in brushless fan, long service life and low noise.
- 3 set shortcut air volume/temperature to simplify operations.
- Support temp lock, temp calibration function.
- Auto standby and sleep function, conserves energy and protect equipment.
- With 10~900s timing function.
- Cold air function to cool components.

Specification

Model	ST-8802	
Voltage	AC 230V±10% 50Hz (110V±10% 60Hz)	
Name	Soldering station	Hot air station
Power	65W	800W
Temperature Range	80°C~480°C	100°C~500°C
Temperature Stability	±2°C	±5°C
Air Flow		120L/min (Max)
The Handle Type	SP-65A	AP-800B
Dimension(Main Unit)	210(L)x125(W)x150(H)mm	
Weight(Main Unit)	≈2.6KG	

Package List

Model	Package List		
ST-8802	Main unit x1	AC cord x1	Manual x1
	Gun holder x1	Ground wire x1	Iron stand x1
	Hot air gun x1	Iron handle x1	Nozzles x3
	Certificate x1		

The left side of the host is the hot air table operation area, and the right side is the welding table operation area



Replacement of Heating Components

Quick replacement of plug-in heating element

T900 Series Soldering Tips

Heater



Nozzle Converter

Can be used with all 850 series nozzles in conjunction with the standard A2000 adapter. 850 series nozzle details in page 35.

Nozzle Converter (Optional)

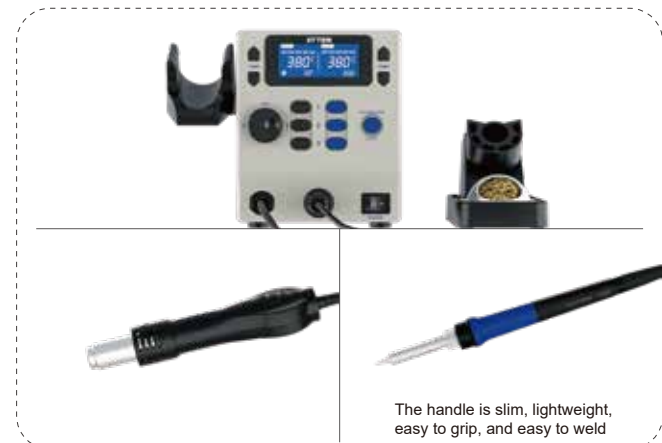

858 series nozzle details in page 34. T900 series soldering tip details in page 18.



Thermal Wire Stripper



Tài liệu được tổng hợp bởi đội ngũ kỹ thuật của **NPOWER**
Bản quyền nội dung thuộc về **Atten**

Powered by **NAVITECH** | www.navitech.co
www.npower.com.vn

■ ST-680D Thermal Wire Stripper 44

ST-680D/ST-680E ESD SAFE

Thermal Wire Stripper

Features

- Standard blade, support process ultra-fine AWG36 wire without damage.
- Integrated host and handpiece design to save space.
- Separated design of handle and heating element, support replace blades simple and conveniently.
- With standby and dormancy functions, reducing energy consumption and improving blade life.

Specification

Model	ST-680D	ST-680E
Voltage	AC 230V±10% 50Hz (110V±10% 60Hz)	
Power	100W	
Temperature range	10%~100% (High temperature 10%~150%)	
Heating principle	Resistance heating	
The handle type	SP-N80	SP-D80
The handle power	≥80W	
Tip-to-ground resistance	<2Ω	
Tip-to-ground potential	<2mV	
Dimension(Main Unit)	201 (L) x84 (W) x195 (H) mm	
Weight(Main Unit)	≈2.74kg	

Package List

Model	Package List		
ST-680D	Main unit x1	Thermal wire stripper x1	Power cord x1
	Grounding wire x1	Copper wire brush x1	
	Screwdriver x1	User manual x1	Certificate x1
ST-680E	Main unit x1	Wire stripper with Knife Handle x1	
	Iron stand x1	User manual x1	Power cord x1
	Certificate x1		



ST-680D

ST-680E

Replacement of Heating Components

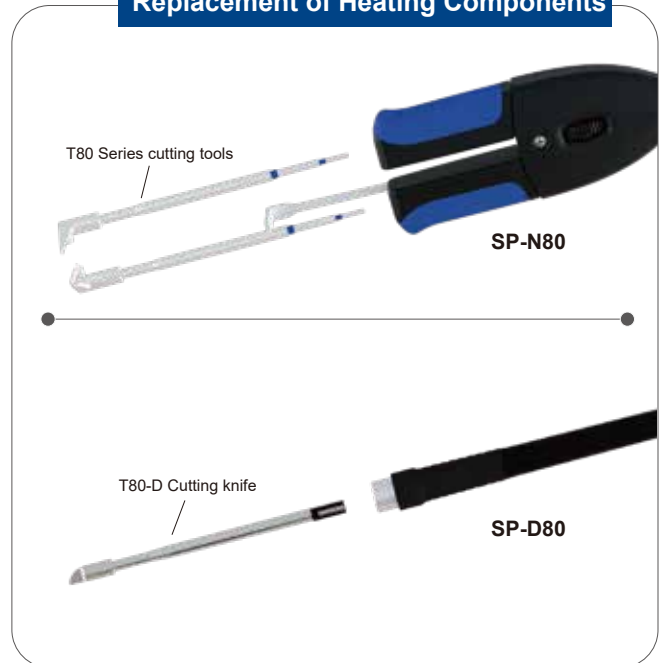

T80 Series cutting tools

SP-N80

T80-D Cutting knife

SP-D80



The handle is placed horizontally for easy use.

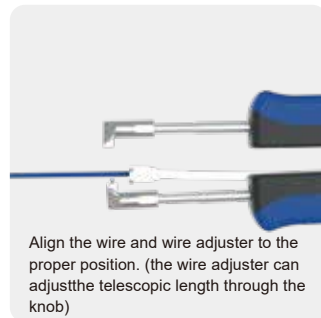

Align the wire and wire adjuster to the proper position. (the wire adjuster can adjust the telescopic length through the knob)

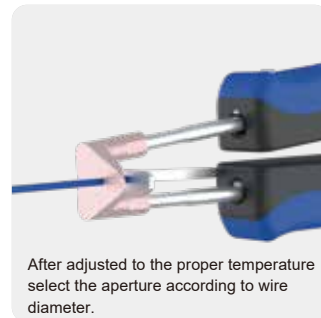

After adjusted to the proper temperature select the aperture according to wire diameter.

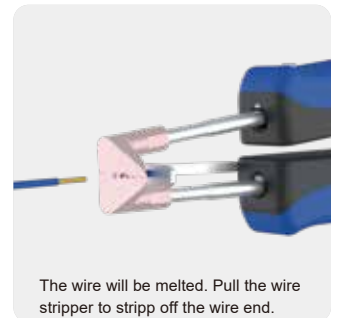

The wire will be melted. Pull the wire stripper to strip off the wire end.

Material Output Value Setting

Material	Output Value
PVC	40%
PE	40%
PA	60%
PVDF	70%
ETFE	75%
SI	75%
PTFE	80%

Note: The above set values may vary depending on the composition and diameter of the wire, and may require higher output values depending on the oxidation and maintenance status of the tool.



ST-680D processing AWG36 wire also doesn't know Causing any damage

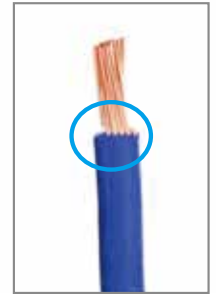

Traditional wire stripping pliers are prone to problems Rough edges and damaged wires

T80 Series Cutting Tools

● Dual-Head Multi-Hole Blade

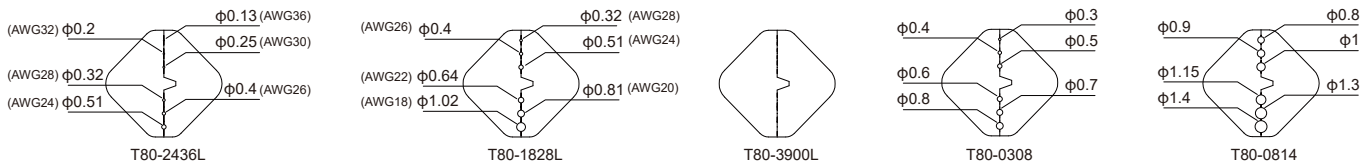

● Single-Head Single-Hole Blade

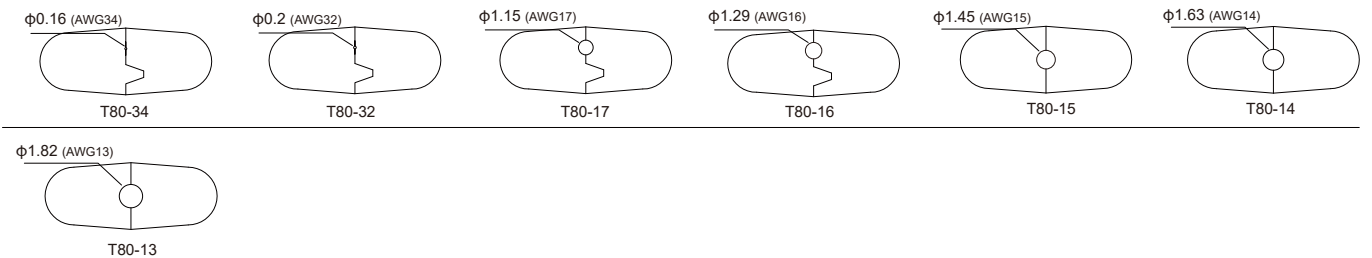

● Single-Head Multi-Hole Blade

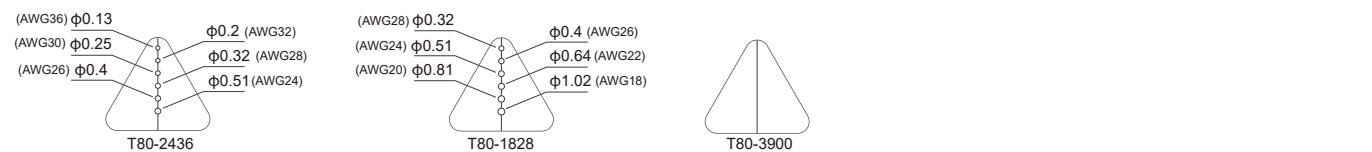

Wire Stripper With Knife

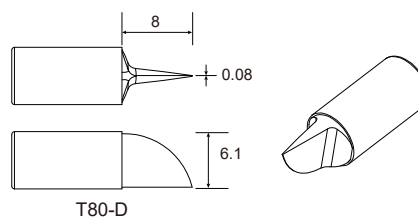



Preheating Platform



Tài liệu được tổng hợp bởi đội ngũ kỹ thuật của **NPOWER**
Bản quyền nội dung thuộc về **Atten**

Powered by **NAVITECH** | www.navitech.co
www.npower.com.vn

■ ST-7500,ST-7800 Preheater	47
■ ST-7242,ST-7322 Preheater	48
■ ST-7700 Preheater	49

ST-7500/ST-7800 ESD SAFE

Preheater

Features

- Three sets of quick parameter design for quick temperature switching.
- Temperature locking function to prevent personnel from mistakenly adjusting the temperature.
- Sensor closed-loop PID control ensures precise and stable temperature.
- Available for preheating circuit boards and other processes that require uniform heating.

Specification

Model	ST-7500	ST-7800
Voltage	AC 230V±10% 50Hz (110V±10% 60Hz)	
Power	450W	850W
Temperature range	50~500°C	50~350°C
Heating area	120x120mm	200x180mm
Heating material	Infrared Ceramic	Aluminum Plate
External K-type thermocouple	Support (temperature measurement range 0~650°C)	
Communication function	Support (RS485 interface)	
Temperature Lock	Support	
Dimensions(Main Unit)	278(L)x203(W)x73(H)mm	355(L)x293(W)x73(H)mm
Weight(Main Unit)	≈2.4kg	≈5.1kg

Package List

Model	Package list		
ST-7500	Main unit x1	Grounding wire x1	Power cord x1
	K-type thermocouple test sensor x1		
ST-7800	User manual x1	Certificate x1	

Preheater Accessories

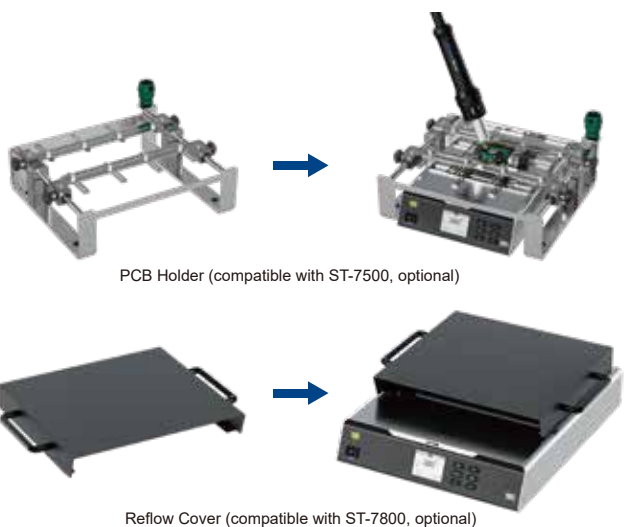

Temperature Measurement

After connecting the K-type thermocouple, the measured temperature data is displayed



Attention: The insertion of the positive and negative poles of the K-type thermocouple must correspond to the positive and negative poles of the machine panel



Connected via RS485 serial port



Online Function

Preheating Section Setting Temperature

ST-7800 Heating Reflow Profile

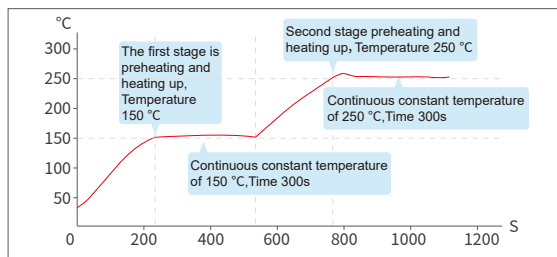

ST-7242/ST-7322

Preheater

Features

- Equipped with four switchable independent working zones, allowing for both independent and combined operation.
- Ensures temperature stability and features temperature compensation for cooling operations.
- Three working modes: temperature mode, power mode, and curve mode.
- Supports three thermocouple modes (control and protection and shutdown), controls and protects thermocouples, and ensures that the PCBA maintains the selected temperature.

Specification

Model	ST-7242	ST-7322
Voltage	AC 230V±10% 50Hz (optional) AC 110V±10% 60Hz (optional)	Three-phase four-wire: AC 380V±10% 50Hz (optional) AC 208V±10% 60Hz (optional) Single-phase source AC 230V±10% 50Hz (optional) AC 110V±10% 60Hz (optional)
Power	2800W(AC 230V) 1200W(AC 110V)	4600W(AC 400V / AC 230V) 4000W(AC 208V / AC 110V)
Temperature Range	50~250°C	50~250°C
Heating Area	120x120mm*4	180x200mm*4
Temperature Sensors	4	
External K-type thermocouple	Support (temperature measurement range 0~650°C)	
Communication function	Support (RS485 interface)	
Temperature Lock	Support	
Dimensions(Main Unit)	320(L)x406(W)x73(H)mm	612(L)x450(W)x73(H)mm
Weight(Main Unit)	≈4.9kg	≈9.1kg

Package List

Model	Package list
ST-7242	Main unit x1 K-type thermocouple test sensor x4 Grounding wire x1 Certificate x1 User Manual x1
ST-7322	Power cord x1(Only ST-7242 contains this accessory)



ST-7242

ST-7322

Temperature Measurement

After connecting the K-type thermocouple, the measured temperature data is displayed.



The Type K thermocouple connectors are connected to the TC1, TC2, TC3, and TC4 interfaces of the device.

(Note: When the TC1 thermocouple connector is not inserted, the system will prompt "TC1 not connected.")



Connected via RS485 serial port



Online Function

Preheater Accessories



Can be used in conjunction with PCB board bracket and hot air gun bracket.



Fixed bracket (ST-703 is suitable for ST-7242, ST-704 is suitable for ST-7322)



Air gun bracket (H-10 is suitable for ST-7242, H-11 is suitable for ST-7322)

ST-7700 ESD SAFE

Preheater

Features

- Equipped with four switchable independent working zones, allowing for both independent and combined operation.
- Ensures temperature stability and features temperature compensation for cooling operations.
- Three working modes: temperature mode, power mode, and curve mode.
- Supports three thermocouple modes (control and protection and shutdown), controls and protects thermocouples, and ensures that the PCBA maintains the selected temperature.



Specification

Model	ST-7700
Voltage	AC 230V~ 50Hz/60Hz (AC 120V~ 60Hz)
Power	700W
Temperature Range	50°C~250°C
Heating Area	120mm*120mm
Temperature Sensors	2
External K-type thermocouple	Support (temperature measurement range 0~650°C)
Communication function	Support (RS485 interface)
Temperature Lock	Support
Dimensions (Main Unit)	215(L)x270(W)x70(H)mm
Weight (Main Unit)	≈2.2Kg

Package List

Model	Package list
ST-7700	Main unit x1 Grounding wire x1 Power cord x1 K-type thermocouple test sensor x2 Certificate x1 User Manual x1

Temperature Measurement

After connecting the K-type thermocouple, the measured temperature data is displayed.



The Type K thermocouple connectors are connected to the TC1 and TC2 interfaces of the device.

(Note: When the TC1 thermocouple connector is not inserted, the system will prompt "TC1 not connected.")



Connected via RS485 serial port



Online Function

Preheater Accessories



PCB Holder (compatible with ST-7700, optional)



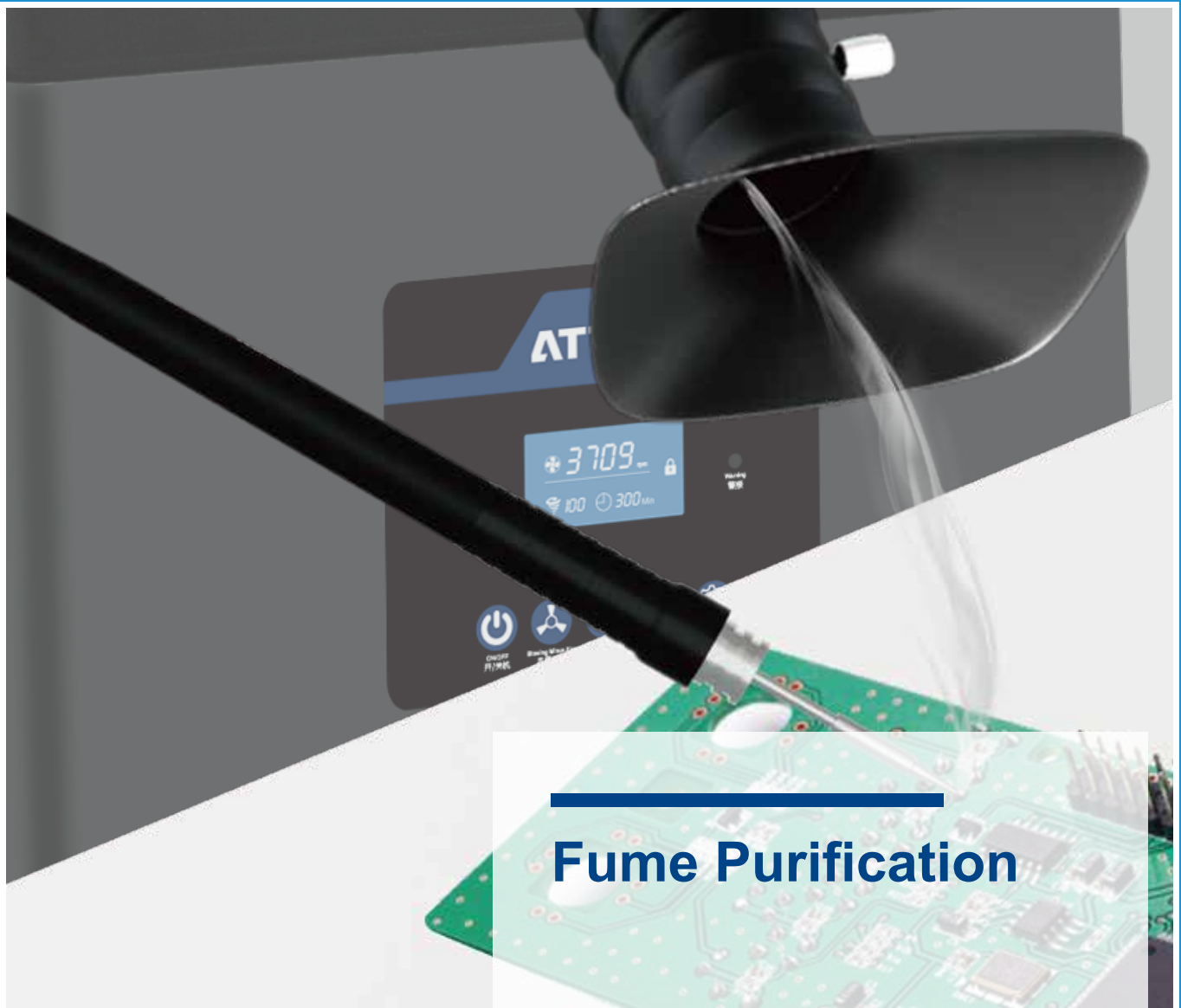

Fume Purification

NPOWER
Powered by
NaviTech

Tài liệu được tổng hợp bởi đội ngũ kỹ thuật của **NPOWER**
Bản quyền nội dung thuộc về **Atten**

Powered by **NAVITECH** | www.navitech.co
www.npower.com.vn

- ST-1101,ST-1101D,ST-1202,ST-1202D Fume Extractor 51
- Solder Smoke Absorber 53

ST-1101/ST-1202/ST-1101D/ST-1202D

Fume Extractor

Features

- Primary, medium, and high-efficiency filters that can be quickly replaced.
- Brushless vortex fan with strong suction power.
- Reduce operational noise.

Specification

Model	ST-1101	ST-1101D	ST-1202	ST-1202D
Voltage	AC 230V±10% 50Hz (110V±10% 60Hz)			
Power	160W		180W	
Work position	1		2	
System flow	240m³/H(±10%)		150m³/H*2(±10%)	
Filter Efficiency (0.3 micron)	99.97%			
IoT Function	No	RS485	No	RS485
Remote control	No	Yes	No	Yes
Flexi tube	1.3m Customizable length			
Dimensions (Main Unit)	465(L)x250(W)x480(H)mm			
Weight	≈17kg		≈18.2kg	

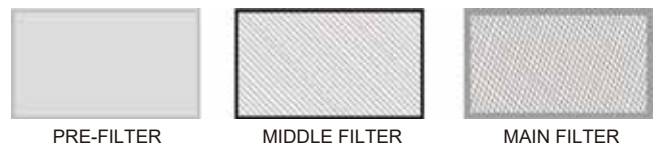
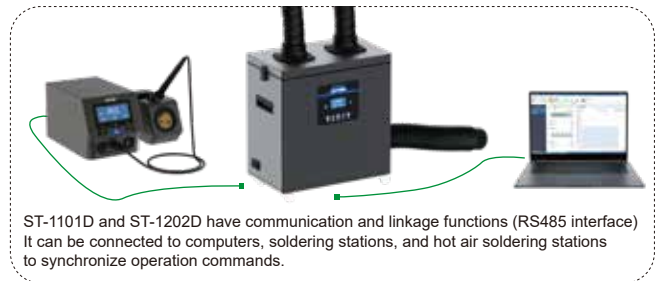
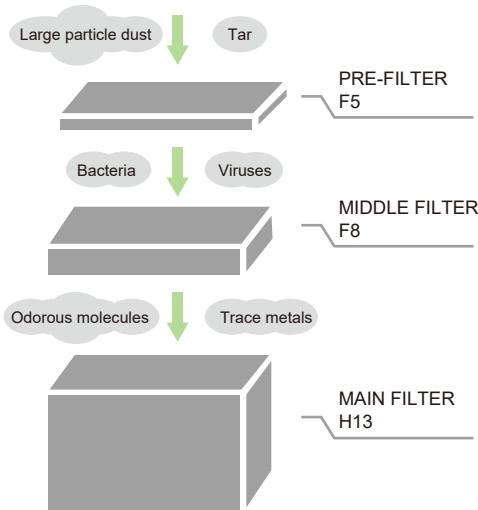

Package List

Model	Package list			
ST-1101	Extractor host x1	Flexi tube x1	Silicone funnel nozzle x1	Primary filter x4 Machine foot pads x4 Power cord x1 User manual x1 PVC duct pipe x1 Certificate x1
ST-1202	Extractor host x1	Flexi tube x2	Silicone funnel nozzle x2	Primary filter x4 Machine foot pads x4 Power cord x1 User manual x1 PVC duct pipe x1 Certificate x1
ST-1101D	Extractor host x1	Flexi tube x1	Silicone funnel nozzle x1	Primary filter x4 Machine foot pads x4 Power cord x1 User manual x1 PVC duct pipe x1 Roller x4 Remote control x1 Certificate x1
ST-1202D	Extractor host x1	Flexi tube x2	Silicone funnel nozzle x2	Primary filter x4 Machine foot pads x4 Power cord x1 User manual x1 PVC duct pipe x1 Roller x4 Remote control x1 Certificate x1



1. The relatively dense side of the pre-filter faces down.
2. The sequence of filters shall be subject to left diagram. Disorganization is strictly forbidden.
3. Suggestions on replacement cycle of filters:
 - a. PRE-FILTER 10-15 days
 - b. MIDDLE FILTER 3-6 months
 - c. MAIN FILTER 6-9 months
 (Remark: The actual replacement cycles of filters shall be subject to the pollution levels of different sites.)

Fume Extractor Accessories

<p>Square transparent exhaust hood</p>  <p>470x370mm</p> <p>D-1375B(for moxibustion)</p>	<p>Square transparent exhaust hood</p>  <p>650x420mm</p> <p>D-1375C(for moxibustion)</p>	<p>Round transparent exhaust hood</p>  <p>φ420mm</p> <p>D-1375D(for moxibustion)</p>	<p>Square Funnel Nozzle</p>  <p>210x130mm</p> <p>D-1375</p>	<p>Round Funnel Nozzle</p>  <p>φ150mm</p> <p>D-1375A</p>	<p>Round Funnel Nozzle</p>  <p>φ150mm</p> <p>D-1375E</p>
<p>Tube connector</p>  <p>φ75mm</p> <p>B-1175</p>	<p>Tube connector</p>  <p>φ75mm</p> <p>B-1175A</p>	<p>Flexible tube</p>  <p>φ75mm</p> <p>A-1075</p>	<p>Flexible tube</p>  <p>φ75mm</p> <p>A-1075A(with valve)</p>	<p>Flexible tube</p>  <p>φ55mm</p> <p>A-1055</p>	<p>Flexible tube</p>  <p>φ55mm</p> <p>A-1055A(with valve)</p>
<p>Extraction arm</p>  <p>450+350+350+200mm</p> <p>A-1063</p>	<p>Extraction arm</p>  <p>450+350+350+200mm</p> <p>A-1063A(with valve)</p>	<p>Main filter</p>  <p>388x202x270mm</p> <p>C-1200A1 (for lampblack)</p>	<p>Washed filter</p>  <p>367x182x18mm</p> <p>C-1200D1 (for lampblack)</p>	<p>Pre-filter</p>  <p>367x182x5mm</p> <p>C-1200D(for lampblack)</p>	<p>Pre-filter</p>  <p>367x182x10mm</p> <p>C-1200C</p>
<p>Medium efficiency filter</p>  <p>367x182x55mm</p> <p>C-1200B</p>	<p>Main filter</p>  <p>388x202x270mm</p> <p>C-1200A</p>	<p>Nylon suction tube</p>  <p>φ80mmx2500mm</p> <p>A-1250</p>	<p>Nylon suction tube</p>  <p>φ80mmx1000mm</p> <p>A-1100</p>	<p>Table clamp</p>  <p>B-1175-2</p>	<p>PVC duct pipe</p>  <p>E-1060</p>



You can choose appropriate accessories, fix them in the right position, and provide more flexible applications.

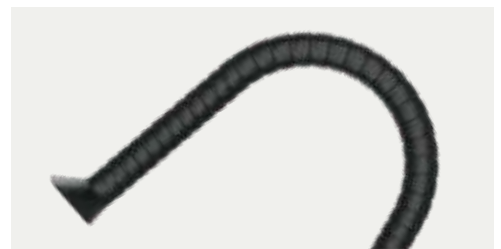

Wanxiang bamboo joint tube can bend freely and be easily placed in smoking areas

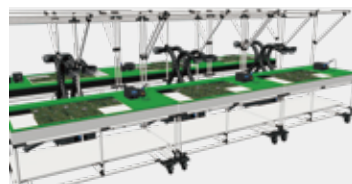

Factory assembly line



Laboratory / Personal Studio

ST-1016/ST-1016-P

Solder Smoke Absorber

Features

This product is a smoking device that quickly eliminates toxic gases. The filter is made of refined activated carbon, Has high absorption capacity and comes with LED lighting function.

Specification

Model	ST-1016	ST-1016-P
Voltage	AC 230V±10% 50Hz (110V±10% 60Hz)	
Power	22W	
Inspiratory Capacity	1.03m³/min	
Dimension	103x162x217mm	
Activated Carbon Size	142x142x10mm	

Package List

Model	Package List
ST-1016	User Manual x1 Activated Carbon Filter x1
ST-1016-P	Solder Smoke Absorber x1

Test Data

Test Item	Test Data
Air volume (vertical) m³/min	1.03
Air volume (horizontal) m³/min	0.4
Air flow (vertical) m/s	1.0
Air flow (horizontal) m/s	2.6
Maximum suction capacity m³/min	1.03

Product Accessories



ST-1016

ST-1016-P

Placed Upright



Lying Horizontally



Easy to replace filter

Pull out this filter on the position, with fingers



ESD Protection



Tài liệu được tổng hợp bởi đội ngũ kỹ thuật của **NPOWER**
Bản quyền nội dung thuộc về **Atten**

Powered by **NAVITECH** | www.navitech.co
www.npower.com.vn

■ ST-1020D,ST-1020DX,ST-1015,ST-1015W Static Eliminator Ion Fan	55
■ AT-FJ1,AT-FJ2 Wrist Strap	56
■ AT-518-1,AT-518-2 Wrist Strap Monitor	56

ST-1020D/ST-1020DX/ST-1015/ST-1015W

Static Eliminator Ion Fan

Features

- The ion neutralization performance reaches $\pm 10V$.
- Which can quickly neutralize static electricity on charged objects.
- Adjustable air volume and supply angle.
- The firing pin is easy to clean and replace.
- Reduce operational noise.

Specification

Model	ST-1020D	ST-1020DX	ST-1015	ST-1015W
Voltage	AC 230V \pm 10% 50Hz (110V \pm 10% 60Hz)			
Power	20W		15W	360W
Heating temperature	No			40~45°C
Air flow	$\leq 2.4m^3/min$			
Static elimination time	$\leq 1.2S$		$\leq 2S$	
Ion balance	$\pm 10V$			
Ion balance adjustable	Yes			
Ion emitting needle	400x1500mm			
Computer Control	RS485	RS485/Antenna	No	
Dimension	146x85x238mm			
Weight	$\approx 3.16KG$		$\approx 2.98KG$	
Standard method	Desktop, Hanging, Clamping			

Package List

Model	Package List		
ST-1020D	Main unit x1	Ground wire x1	User manual x1
ST-1020DX	Power cord x1	Remote control x1	Certificate x1
ST-1015	Main unit x1	Ground wire x1	User manual x1
ST-1015W	Power cord x1	Certificate x1	



Product Accessories



AT-FJ1/AT-FJ2

Wrist Strap

Features

- Strong anti-static properties, the wristband can dissipate static electricity from the human body.
- The wristband has high safety performance and is made of thermoplastic material, making it lightweight.
- Thin and soft, safe in contact with human skin, and easy to use.
- Strong resistance, the impedance of the wristband can reach 10000Ω.



Can be used alone or in combination with crocodile clips



AT-FJ1

AT-FJ2

AT-518-1/AT-518-2

Wrist Strap Monitor

Features

- Real time monitoring of the operator's wearing of the static wrist strap and the connection of the ground wire to the ground, and automatic alarm immediately in case of abnormal conditions.
- Easy to use, it can correctly determine the contact between the ground wire of the ground and the ground wire of the workbench.
- Chip control, no debugging, plug and play.
- Good reliability and strong anti-interference ability.
- High sensitivity, when the static discharge path malfunctions, the monitor will sound an alarm.

Model	AT-518-1	AT-518-2
Work position	1	2
Voltage	220V	
Output	6VDC	
Size	62x45x29mm	103x56x29mm
Weight	41g	74g



AT-518-1

AT-518-2



Tool Accessories



Tài liệu được tổng hợp bởi đội ngũ kỹ thuật của **NPOWER**
 Bản quyền nội dung thuộc về **Atten**

Powered by **NAVITECH** | www.navitech.co
www.npower.com.vn

■ GT-6081,GT-6080 Tip Cleaner	58	■ TJ-227,TJ-228 Solder Wire Stand	61
■ ST-1090 Temperature tester	59	■ TJ-227A,TJ-227B Solder Wire Stand	61
■ JQ-010,JQ-050,JQ-100A Hot Melting Glue Gun	60	■ TR-045 Rosin Flux,AT-F10 Tip Refresher	61
■ LT-360B,LT-350B,LT-380B,LT-310B Solder Pot	60	■ AT-H20,AT-H40,AT-H60 Paste Flux	61
■ S-11 Solder Iron stand	61	■ AT-E330A,AT-E330P Desoldering Tool	61
■ CS-05B Tip Cleaner	61	■ AT-E210D Desoldering Tool	61
■ CS-08B Solder Dross Box	61	■ AT-B778 Vacuum Pick-up Tool	61
■ FT-90A Magnifying Frame	61	■ Soldering Wire	62
		■ Soldering Wick	63

GT-6081/GT-6080 ESD SAFE

Tip Cleaner

Features

- Intelligent infrared sensing automatic cleaning, enhancing user experience.
- Effectively removes oxidation from the surface of the soldering tip.
- The brush head is easy to replace, improving work efficiency.

Specification

Model	GT-6081	GT-6080
Adapter	AC 100-240V,50/60Hz, DC 24V/1A	
Power	4W	6W
Motor Speed	250-350 r/min	500-1000 r/min
Trigger Type	Sensor	
Noise	<60dB	
Rotation Protection	Resistance monitoring	
Alarm Indicator Lamp	The red light is out of order, the green light is normal	
Dimensions	90x130x60mm	90x120x85mm
Weight	≈0.7kg	≈0.44kg

Package List

Model	Package list
GT-6081	Main Unit x1PC ESD Wire x1PC AC Adapter x1PC Plug Adapter: CN x1PC,UK x1PC, EU x1PC,US x1PC Tip Tinner x1PC Hand Brush x1PC Certificate x1PC User Manual x1PC
GT-6080	Main Unit x1PC ESD Wire x1PC AC Adapter x1PC Plug Adapter: CN x1PC,UK x1PC, EU x1PC,US x1PC Certificate x1PC User Manual x1PC



Optional Accessory

Model	Name	Cleaning	PIC
BR-01	Metal brush	Intensive	
BR-02	Fiber brush	Gentle	
BR-03	Hand brush (Only standard on GT-6081)	Intensive	
BR-04	Stainless steel brush	Intensive	



AC Adapter

Plug Adapter Picture

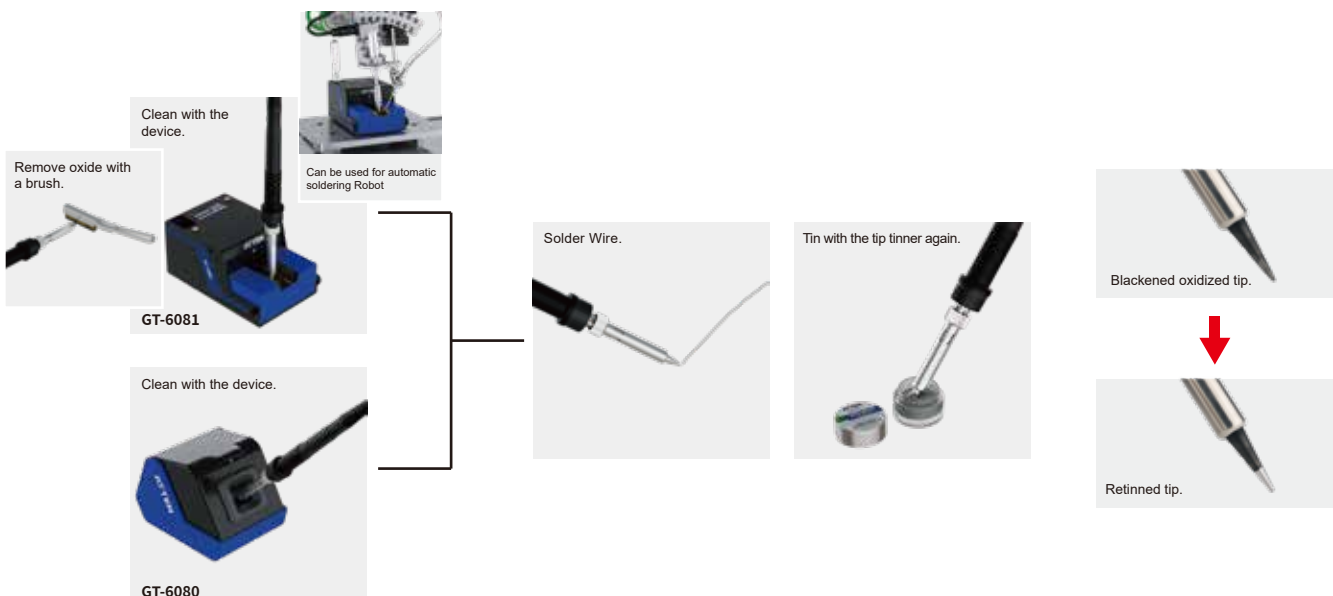

NOTE: A tip temperature of 300°C (512°F) is the most suitable for cleaning.

ST-1090

Tip Temperature Tester

Features

- The sensor is made of 0.2mm metal wire and is suitable for quickly measuring the temperature of the welding nozzle.
- If the thermometer is not in use for 15 minutes (adjustable), it will automatically shut down.
- Equipped with a "MAX HOLD" function to record the highest temperature of the welding nozzle, avoiding human error.

Specification

Model	ST-1090
Resolution	1°C/1°F
Temperature Range	0~800°C/32~1500°F
Accuracy Temperature	±5°C/±9°F
Sensing Wire	K-type thermocouple
Power	9V DV High-performance Alkaline battery
Operating Environment	0~40°C/32~104°F
Dimension	75x143.5x41.5mm
Weight	≈185g

Note: The sensor is only suitable for measuring temperatures below 500 °C. If measuring higher temperatures, please use a suitable temperature probe.

Package List

Model	Package list
ST-1090	Host ST-1090 x1 Battery x1 Manual x1 K-type thermocouple test wire x1 Test report x1 Certificate x1 MINI USB data line x1 Sensor x10

Serial Port Function

The serial port data line is connected to the thermometer and the computer, the thermometer displays COM as shown in Figure 4-2; the thermometer sends to the computer every 100ms temperature data.



ATTEN serial port assistant



Figure4-2 (Serial communication baud rate 9600)

Download ATTN serial port assistant from the official website(You can also use other serial port assistants)

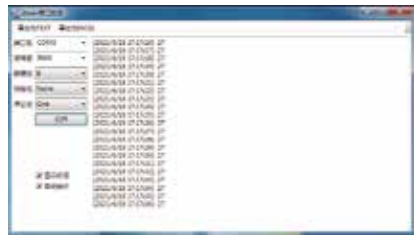

ATTEN Serial Assistant Interface

Note:convert serial communication, the computer needs to install the CH340 chip driver



Short press the "MAX HOLD" button to open the highest temperature holding interface, avoiding human error



Display the number of temperature measurements and record the current usage of the sensor for easy determination of replacement cycles



Combined with the Atten soldering station (with infrared function), one key temperature calibration can be achieved

JQ-010/JQ-050/JQ-100A

Hot Melting Glue Gun

Features

The hot melt glue gun can quickly melt the glue stick and be used to stick clean, dry, and lubricant free objects.

Model	JQ-100A	JQ-050	JQ-010
Voltage	110~240V		3.6V(lithium battery)
Power	100W	50W	8-10W
High temperature	200°C	180°C	180°C
Glue stick	φ11mm	φ7mm	φ7mm



Glue Stick



φ11mm



φ7mm

LT-360B/LT-350B/LT-380B/LT-310B

Solder Pot

Features

Using Tieming aluminum wire heating core and ceramic tube insulated lead, it heats up quickly and is more durable. It is suitable for dissolving substances such as tin, glue, and grease that are prone to condensation at room temperature/low temperature. It heats up quickly, conducts heat evenly, has stable temperature, and has a longer lifespan.

Specification

Model	LT-360B	LT-350B	LT-380B	LT-310B
Voltage	220V~240V			
Power	130W	160W	250W	300W
Temperature range	50-520°C	50-520°C	50-480°C	50-480°C
Solder capacity	0.3kg	0.5kg	1.6kg	2.2kg
Crucible size	φ36mm	φ50mm	φ80mm	φ100mm
Melting time	10min	10min	20min	20min

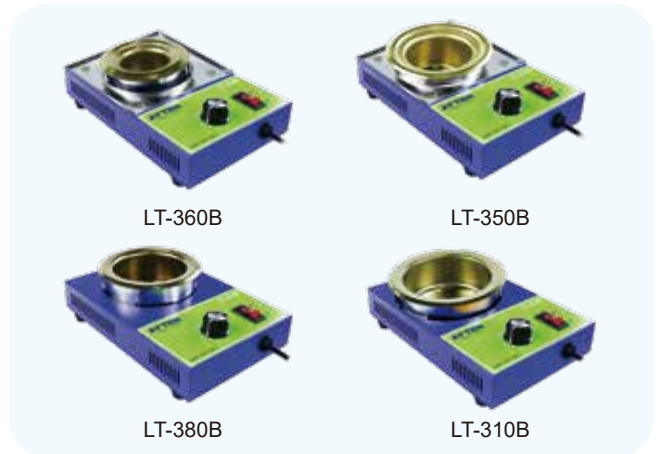

Accessories



S-11 Solder Iron Stand

All-metal construction.
Portable solder stand which helps.
Work more convenience.
The tilt angle is adjustable.



CS-05B Tip Cleaner

The soldering tip is cleaned by wiping or turning it in the metal wool. subsequently, a fine solder layer will remain which prevents fast oxidation of the soldering tip, and represents a considerable advantage compared to standard sponge cleaning.



CS-08B Solder Dross Box

Special for lean soldering tip and recycling tin residue. Anti-static / high temperature resistance. Pour out the tin block easily. Improving the problem of throwing tin while soldering, dirty and messy working environment, convenient to mass collect and take out after collecting, etc.



FT-90A Magnifying Frame

Made up of steel base, movable mechanical arm, fixed frame and magnifying glass. adjust proper height. The components can be adjusted in any direction. Use for observation /repair / circuit board (especially high-density, precision circuit board) welding of small objects as an extensive maintenance tool.



TJ-227 Solder Wire Stand

The metal steel plate chassis is stable and elegant. The metal shaft can withstand 1KG tin solder. The shaft is easy to disassemble; Flexible rotation.



TJ-228 Solder Wire Stand

All-metal construction. Simple design. Soldering wire holder and sponge plate 3 in 1. Save space, use easily.



TJ-227A / TJ-227B Solder Wire Stand

Metal steel plate chassis, with easy disassembly of the shaft and flexible rotation.



TR-045 Rosin Flux

Remove oxidation film. Prevent oxidation. Reduce surface tension.



AT-F10 Tip Refresher

Remove the oxidized black layer from the soldering iron tip and re solder the tip, Environmentally friendly, free of harmful substances, reusable multiple times.



AT-H20 / AT-H40 / AT-H60 Paste Flux

Antioxidant, easy to tin, minimal residue, no need for cleaning, low volatility, safe and reliable.



AT-E330A / AT-E330P / AT-E210D Desoldering tool

















Automatic rebound, high tin suction force, effortless pressing, anti slip handle, easy cleaning.



AT-B778 Vacuum pick-up tool

Easy to operate, multi specification suction cups, convenient to carry.

Soldering Wire

Category		Weight	Model / Wire diameter	Model / Wire diameter	Model / Wire diameter
Soldering Wire	LEAD FREE Composition Proportion Sn99.3% Cu0.7% Melting point 217 ~220°C	 50g	Model: TS-99.35050 Wire diameter: 0.5mm	Model: TS-99.38050 Wire diameter: 0.8mm	Model: TS-99.3A050 Wire diameter: 1mm
		 100g	Model: TS-99.35100 Wire diameter: 0.5mm	Model: TS-99.38100 Wire diameter: 0.8mm	Model: TS-99.3A100 Wire diameter: 1mm
		 500g	Model: TS-99.35500 Wire diameter: 0.5mm	Model: TS-99.38500 Wire diameter: 0.8mm	Model: TS-99.3A500 Wire diameter: 1mm
	LEADED Composition Proportion Sn63% Pb37% Melting point 183~184°C	 50g	Model: TS-635050 Wire diameter: 0.5mm	Model: TS-638050 Wire diameter: 0.8mm	Model: TS-63A050 Wire diameter: 1mm
		 100g	Model: TS-635100 Wire diameter: 0.5mm	Model: TS-638100 Wire diameter: 0.8mm	Model: TS-63A100 Wire diameter: 1mm
		 500g	Model: TS-635500 Wire diameter: 0.5mm	Model: TS-638500 Wire diameter: 0.8mm	Model: TS-63A500 Wire diameter: 1mm
Tin-silver Soldering Wire	Low Silver Composition Proportion Sn99% Cu0.7% Ag0.3% Melting point: 216°C~227°C	 50g	Model: TS-Ag0.35050 Wire diameter: 0.5mm	Model: TS-Ag0.38050 Wire diameter: 0.8mm	Model: TS-Ag0.3A050 Wire diameter: 1mm
		 100g	Model: TS-Ag0.35100 Wire diameter: 0.5mm	Model: TS-Ag0.38100 Wire diameter: 0.8mm	Model: TS-Ag0.3A100 Wire diameter: 1mm
		 500g	Model: TS-Ag0.35500 Wire diameter: 0.5mm	Model: TS-Ag0.38500 Wire diameter: 0.8mm	Model: TS-Ag0.3A500 Wire diameter: 1mm
	Silver Composition Proportion Sn96.5% Cu0.5% Ag3% Melting point: 217°C~220°C	 50g	Model: TS-Ag035050 Wire diameter: 0.5mm	Model: TS-Ag038050 Wire diameter: 0.8mm	Model: TS-Ag03A050 Wire diameter: 1mm
		 100g	Model: TS-Ag035100 Wire diameter: 0.5mm	Model: TS-Ag038100 Wire diameter: 0.8mm	Model: TS-Ag03A100 Wire diameter: 1mm
		 500g	Model: TS-Ag035500 Wire diameter: 0.5mm	Model: TS-Ag038500 Wire diameter: 0.8mm	Model: TS-Ag03A500 Wire diameter: 1mm
Stainless Steel Tin Soldering Wire (Can not be used for PCB board welding.)	Special for stainless steel soldering Composition Proportion Sn99.3% Cu0.7% Melting point: 217°C~220°C	 50g	Model: TS-99.38080S Wire diameter: 0.8mm	Model: TS-99.3A050S Wire diameter: 1mm	Model: TS-99.3C050S Wire diameter: 1.5mm
		 500g	Model: TS-99.38500S Wire diameter: 0.8mm	Model: TS-99.3A500S Wire diameter: 1mm	Model: TS-99.3C500S Wire diameter: 1.5mm
	Special for stainless steel soldering Composition Proportion Sn50% Pb50% Melting point: 200°C~216°C	 50g	Model: TS-Sn508050S Wire diameter: 0.8mm	Model: TS-Sn50A050S Wire diameter: 1mm	Model: TS-Sn50C050S Wire diameter: 1.5mm
		 500g	Model: TS-Sn508500S Wire diameter: : 0.8mm	Model: TS-Sn50A500S Wire diameter: : 1mm	Model: TS-Sn50C500S Wire diameter: 1.5mm

Soldering Wick

Picture	Model	Width	Length
 <p>Soldering wick</p>	AT-0815	0.8mm	1.5m
	AT-1515	1.5mm	1.5m
	AT-2015	2.0mm	1.5m
	AT-2515	2.5mm	1.5m
	AT-3515	3.5mm	1.5m
	AT-0820	0.8mm	2.0m
	AT-1520	1.5mm	2.0m
	AT-2020	2.0mm	2.0m
	AT-2520	2.5mm	2.0m
	AT-3520	3.5mm	2.0m



ISO9001:2015



Engineers' partner