



# Digit Outside Micrometer

## Safety Precautions

To ensure operator safety, use this product according to the directions, functions and specifications given in this User's Manual.

Use under other conditions may compromise safety.

**CAUTION** Shows risks that could result in minor or moderate injury.

Always handle the sharp measuring faces of this product with care to avoid injury.

**NOTICE** Shows risks that could result in property damage.

- Do not disassemble or modify. Doing so will void the warranty.
- Do not use or store the product in a place with sudden temperature changes. Also, before using the product, allow it to acclimate to room temperature.
- Do not store the product in a place with high humidity or a lot of dust.
- Do not use the product in a place where it may contact water, etc.
- Do not apply excessive force or subject to sudden impacts such as dropping.
- Do not rotate the thimble rapidly.
- Use a soft, lint-free cloth to wipe dirt off of the product. Do not use detergents or organic solvents such as thinner.
- Do not write on the product, such as numbers, with an electric pen.

## Contents

1. Names of Components .....	Page 1
2. Precautions for Use .....	Page 1
3. Reference Point Setting .....	Page 1
4. Measurement Method .....	Page 2
5. How to Read Graduations .....	Page 2
6. Adjustment of Rotational Play in the Spindle .....	Page 2
7. Specifications .....	Page 2
8. Paid Maintenance .....	Page 2

## 1. Names of Components

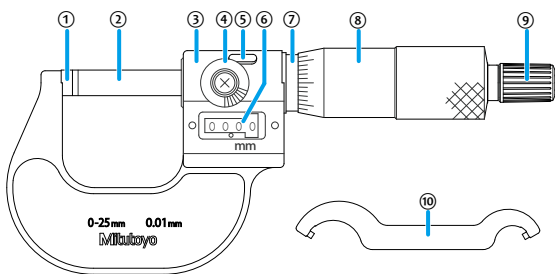

- |           |                |
|-----------|----------------|
| ① Anvil   | ⑥ Counter      |
| ② Spindle | ⑦ Sleeve       |
| ③ Frame   | ⑧ Thimble      |
| ④ Clamp   | ⑨ Ratchet stop |
| ⑤ Cap     | ⑩ Key wrench   |

Figure 1

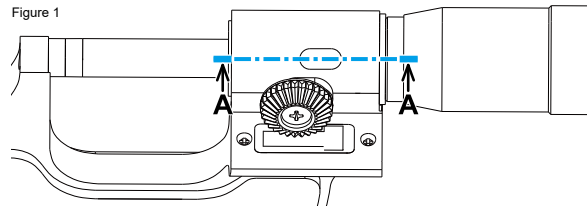

Cross section of A-A in Figure 1

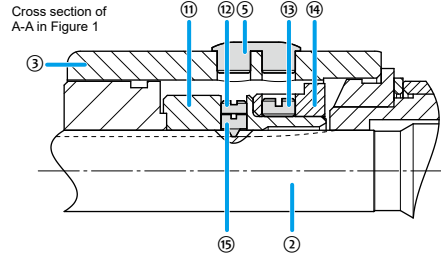

- |                    |             |
|--------------------|-------------|
| ⑪ Clamp ring       | ⑭ Gear      |
| ⑫ Key clamp screw  | ⑮ Key screw |
| ⑬ Adjustment screw |             |

## 2. Precautions for Use

### Parallax

- Due to the way this product is constructed, the plane of the reference line on the sleeve is not on the same plane as the graduation line on the thimble, so the point where the two lines meet will be viewed differently depending on the position of your eyes. When reading measured values, do so perpendicular from the point where the reference line on the sleeve meets the graduation line on the thimble (see the figure on the right).
- If you are looking from a different direction (as in the figure on the right), be aware that there will be a parallax of roughly 2 μm.

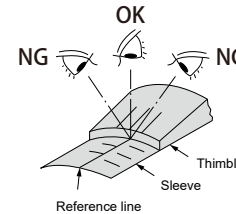

### Measuring Force

- When measuring, always use the ratchet stop to ensure a consistent measuring force.
- To achieve an appropriate measuring force, make light contact between the measurement surfaces and the workpiece, and then rotate the ratchet stop about three to five times with your fingers. Note that excessive measuring force may cause errors.

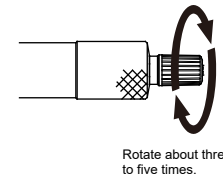

### Precautions and Cleaning after Use

- After use, check that none of the parts are damaged, and clean the entire spindle with a soft, lint-free cloth.
- If oil, cutting fluid, or other fluids harden on the product or if dirt is difficult to remove, put some volatile cleaning liquid (such as cleaning alcohol) on a soft, lint-free cloth, and use that to clean the product.
- After use, apply some Micrometer Oil (Part No. 207000) to the entire spindle to prevent rust from forming.
- If using in places exposed to water-based cutting fluid, always apply anti-rust treatment after cleaning.
- If Micrometer Oil is not available and you must use a commercially available product, we recommend using an anti-rust agent with low viscosity of around ISO VG 10.
- For storage, release the clamp.

## 3. Reference Point Setting

### IMPORTANT

- When measuring, be sure to follow the procedure in steps 1 to 3 below to confirm and set the reference point.
- For the reference point setting for this product, use a calibrated gage (gauge block, setting standard for outside micrometer, etc.).
- Remove any dirt or oil from the measurement surfaces of the gage and product prior to setting the reference point.
- Use the same orientation and conditions as when measuring to set the reference point.

1 Remove any dirt or dust from the measurement surfaces of the calibration gage and the product.

2 For 0 to 25 mm measurement range:  
After making light contact with both measurement surfaces, stop momentarily, and then apply the appropriate measuring force (see "Measuring Force" in "2. Precautions for Use").

For above the 0 to 25 mm measurement range:  
After clamping the gage between the measurement surfaces, bring the spindle measurement surface into light contact with the gage, stop momentarily, and then apply the appropriate measuring force (see "Measuring Force" in "2. Precautions for Use").

3 Read the counter display value and the graduation on the thimble, and if the reading matches the size of the gage, you may start measuring. If they do not match, make adjustments as follows.

• If the reference point difference is ±0.01 mm or less (Figure 2)  
Insert the included key wrench into the hole on the rear of the reference line on the sleeve, and then rotate the sleeve until the reference line is aligned with the zero graduation line on the thimble.

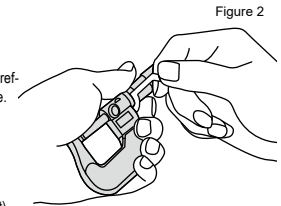

• If the reference point difference is around ±0.01 mm or higher (Figure 3)

1 Loosen the ratchet stop with the key wrench.

2 Push the thimble to the outside (in the direction of the ratchet) so that it can be moved freely, and then align the zero graduation line on the thimble with the reference line on the sleeve.

3 Tighten the ratchet stop with the key wrench and secure the thimble back into place.  
If the zero point is slightly off, adjust according to "• If the reference point difference is ±0.01 mm or less".

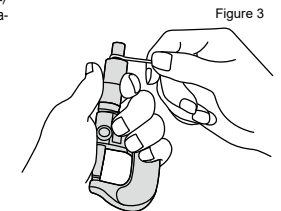

• If the counter indicates a different display value

1 Set the reference point, and confirm the difference with the counter display value.

2 Remove the cap. (Figure 4)

3 Rotate the thimble while looking into the inside of the right hole to align the adjustment screw (13 in "1. Names of Components") with the hole position.

4 Loosen the adjustment screw with a precision screwdriver to stop the counter. While holding down the adjustment screw, turn the thimble the amount of the difference that was confirmed on the counter display value in 1 to match the counter display value and the graduation line on the thimble, and then tighten the adjustment screw.

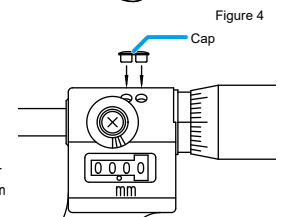

5 Set the reference point again, and then check whether the counter display value was adjusted to 00.00.

If the value is still different, repeat the procedure in 4. (Repeat the adjustment until 00.00 is displayed.)

6 Attach the cap.



Tài liệu được tổng hợp bởi đội ngũ kỹ thuật của **NPOWER**  
Bản quyền nội dung thuộc về **Mitutoyo**

Powered by **NAVITECH** | www.navitech.co  
**www.npower.com.vn**

#### 4. Measurement Method

##### IMPORTANT

- To obtain accurate measurements, be sure to perform reference point setting before measurement.
- Bring the measurement surface of the spindle slowly into contact with the workpiece. Moving too quickly could deform the workpiece and affect measurement results.

When measuring, gradually and lightly bring the measurement surfaces into contact with the workpiece using the same orientation and procedure as for reference point setting, apply the appropriate measuring force, and then read the measured value. (See ■ Measuring Force" in "2. Precautions for Use".)

#### 5. How to Read Graduations

##### ■ 0.001 mm Graduation Type

Vernier graduation lines are above the reference line on the sleeve.  
Read the graduations as follows.

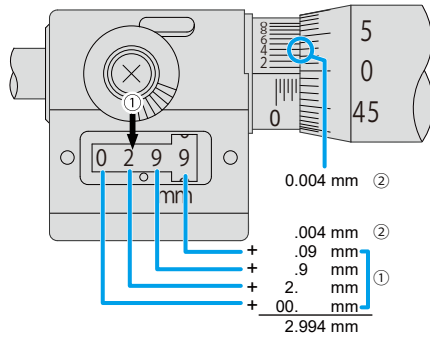

For "0.004 mm" in ②, read the location where the vernier graduation line meets the graduation line on the thimble.

##### ■ 0.01 mm Graduation Type

Read the graduations as follows.

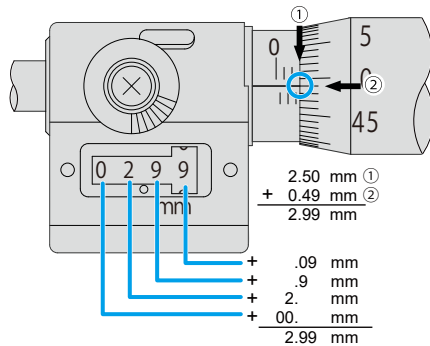

For "0.49 mm" in ②, read the location where the reference line on the sleeve meets the graduation line on the thimble. This is normally read up to a graduation of 0.01 mm (as shown in the figure above). However, it is also possible to visually read up to a graduation of 0.001 mm (as shown in the figure below).

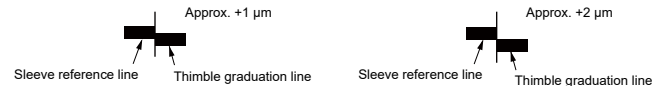

#### 6. Adjustment of Rotational Play in the Spindle

If there is play in the rotation of the spindle, make adjustments as follows.

- 1 Remove the cap.
- 2 Rotate the thimble while looking into the inside of the left hole to align the key clamp screw with the hole position, and then tighten the clamp.
- 3 Remove the key clamp screw with a precision screwdriver, lightly tighten the key screw, and then attach the key clamp screw again.
- 4 Loosen the clamp, and then check the operation of the spindle.
- 5 Attach the cap.

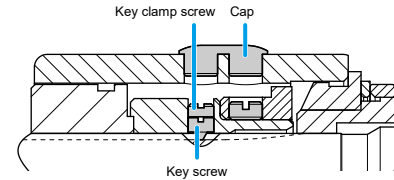
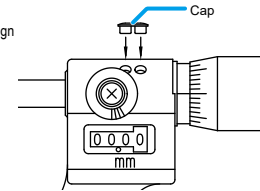

##### Tips

It may be impossible to obtain the specified accuracy depending on the adjustment method. If this occurs, it will require off-site repairs.

#### 7. Specifications

##### ■ Common Specifications

Graduation: 0.01 mm, 0.001 mm (for types with vernier graduation lines only)  
0.0001 in

Temperature range: 5 °C to 40 °C (operating temperature), -10 °C to 60 °C (storage temperature)

Standard accessories: Key wrench (No. 301336), setting standard (equipped as standard with products with measurement range exceeding 25 mm)

##### ■ Individual Specifications

Maximum measuring length	Maximum permissible error $J_{MPE}^{*1}$
25-75 mm	$\pm 2 \mu$ m
100 mm	$\pm 3 \mu$ m
1-3 in	$\pm 0.0001$ in
4 in	$\pm 0.00015$ in

\*1: Maximum permissible error for indicated value via contact with full measuring face  $J_{MPE}$  (20 °C)

#### 8. Paid Maintenance

We recommend periodic inspections to check and maintain the product's accuracy. Also, if any of the following defects occur, please contact the agent where you purchased the product or a Mitutoyo sales office.

- Faulty spindle operations  
Scratches on the spindle may cause interference while the spindle is retracting, causing faulty operations.  
Rust on the spindle may also cause faulty operations.
- Inconsistent measured values  
Burr or nicks generated by an impact on the measurement surfaces may affect measurement repeatability.



Tài liệu được tổng hợp bởi đội ngũ kỹ thuật của **NPOWER**  
Bản quyền nội dung thuộc về **Mitutoyo**

Powered by **NAVITECH** | www.navitech.co

**www.npower.com.vn**