

QuantuMike MD-E



Safety Precautions

To ensure operator safety, use this product according to the directions, functions and specifications given in this User's Manual. Use under other conditions may compromise safety.

WARNING Shows risks that could result in death or serious injury.

- Keep batteries out of reach of children. If one is swallowed, consult a physician immediately.
- Batteries should never be short-circuited, disassembled, or come into contact with extreme heat or flames.
- If battery liquid leaks out, and the liquid comes into contact with the skin or clothing, flush the exposed area thoroughly with clean water. If battery liquid comes into contact with your eyes, flush the eyes immediately with clean water and consult a physician.

CAUTION Shows risks that could result in minor or moderate injury.

- Do not attempt to charge the battery. It is not rechargeable. Properly orient the positive-negative terminals when inserting the battery. Inserting the battery improperly could cause the battery to leak or rupture, resulting in injury or damage to the equipment.
- The measuring faces of this product are sharp. Handle them with sufficient care to avoid bodily injury.

NOTICE Shows risks that could result in property damage.

- Do not disassemble or modify the product. Doing so will void the warranty.
- Do not use or store the product in a place with sudden temperature changes. Adapt the product to room temperature before use.
- Do not store the product in a place with high humidity or a lot of dust.
- If the product is used in a place exposed to direct splashes of coolant, etc., firmly close the battery compartment cover. When attaching the cover, connection cable, etc., firmly tighten the fixing screws so that there are no gaps. Also, clean the product and apply anti-rust treatment after use. Rust may cause malfunction.
- Do not use submerged, as coolant ingress cannot be completely prevented. If the product is used in a place exposed to direct jets of liquid, complete prevention of the ingress of coolant, etc., may also not be possible depending on how the product is used.
- Do not apply excessive force to or subject the product to sudden impacts such as dropping.
- Remove dust, cutting chips, etc., before and after use.
- Remove any dirt on the product by wiping it gently with a soft lint-free cloth. Do not use organic solvents such as cleaning agents or thinner.
- The spindle moves quickly: One rotation of the thimble moves the spindle 2 mm. Do not allow the measurement surfaces to come into contact with force while measuring or setting the origin.
- The spindle structure prevents it from being pulled out, so do not try to forcibly retract it in excess of the measurement range.
- Dirt on the spindle may lead to malfunction. If the spindle becomes dirty, wipe it clean with a cloth containing a small amount of alcohol, and apply a small amount of Micrometer Oil (Part No. 207000). If Micrometer Oil is unavailable and the only option is a commercial product, we recommend low-viscosity anti-rust oil of ISO VG 10 or so.
- Do not write numbers, etc., with an electric pen.
- If the product will not be used for three months or longer, remove the battery before storage. Liquid leakage from the battery may damage the product.

Contents

1. Overview	Page 1
2. Precautions for Use	Page 1
3. Names of Components	Page 2
4. Installing the Battery	Page 2
5. Common Operations	Page 2
5.1 Turning the Power On and Off	Page 2
5.2 Switching the Units (mm/in; Inch Models Only)	Page 2
5.3 Switching the Measurement Type (ABS/INC)	Page 2
5.4 Setting the Display to Zero (in INC Measurement)	Page 2
5.5 Setting/Releasing the Display-Value Hold	Page 2
5.6 Setting ORIGIN	Page 3
6. Measurement Method	Page 3
7. Other Operations	Page 4
7.1 Selecting the Function Setting Mode	Page 4
7.2 Changing the Units [unit]	Page 4
7.3 Performing Tolerance Judgment [tol.]	Page 4
7.4 Using the Calculation Function [calc.]	Page 5
7.5 Selecting the Approach Speed Warning Function [A-S]	Page 5
7.6 Customizing the Key Operation Settings [S-sel]	Page 5
7.7 Preventing Accidental Operation by Locking the Functions [F-loc]	Page 6
7.8 Selecting the Calibration Schedule Alert [Cal.alt]	Page 6
7.9 Selecting the Auto ON Function [A-on]	Page 7
7.10 Selecting the Auto OFF Function [A-off]	Page 7
7.11 Resetting All Settings [reset]	Page 7
8. Error Displays and Troubleshooting	Page 8
9. Specifications	Page 8
10. Input/Output Functions	Page 8
11. Optional Accessories	Page 9
12. Off-Site Repairs (Subject to Charge)	Page 9

1. Overview

This product is a multi-function Digimatic micrometer.

It has the following features.

- Tolerance judgment function
The measured value is judged based on whether it is within the set lower and upper tolerance limits, and the result is displayed as an icon.
- Calculation function (Ax+B)
The counter value (x) is multiplied by a coefficient A, and another coefficient B is added to that product.
- Approach speed warning function
The movement speed of the spindle is calculated just before it makes contact with the workpiece, and if the speed exceeds a threshold, the displayed value blinks.
- Key operation customization function
Operation keys can be customized by changing the functions assigned to them.
- Key operation lock function
The ORIGIN function and ZERO/ABS function can be disabled to prevent the origin from being changed inadvertently.
- Calibration schedule alert function
An alert is displayed to notify you of the calibration schedule.

- Auto OFF function
The power automatically turns off after 20 minutes of inactivity.
- Auto ON function
When the product is off, the power automatically turns on when the ratchet thimble is turned 1/8 of a rotation or more or when a key is operated.
- Data input/output function
This product supports output of the displayed value to a peripheral device via DIGIMATIC d1 or bidirectional serial I/O with a peripheral device via DIGIMATIC S1.

2. Precautions for Use

■ Precautions for the Auto OFF function

- When the Auto OFF function is activated, this product automatically turns off after 20 minutes of inactivity. To turn on the product again, rotate the ratchet thimble or operate one of the keys.
- The Auto OFF function can be activated or deactivated in the function setting mode. (See "7.10 Selecting the Auto OFF Function [A-off].")

■ Precautions for measurement

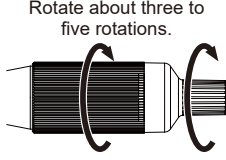
- Be sure to apply a steady measuring force to the workpiece when performing measurements. A steady measuring force is achieved by bringing the measurement surfaces into light contact with the workpiece and then further rotating the ratchet thimble three to five rotations with your fingers. An excessive measuring force can cause errors.
 
- Also, the applied measuring force differs depending on which part (thimble or speeder) you are holding when you rotate the ratchet thimble. Be sure to hold the same part as you did when you performed the ORIGIN setting.
- The spindle moves quickly: One rotation of the ratchet thimble moves the spindle 2 mm. Bring the measurement surfaces into contact gently while measuring or setting the origin.
- Use caution when measuring magnetized workpieces. If the product becomes magnetized, measurement results may be affected.

■ Precautions and cleaning after use

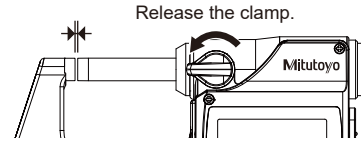
- After use, check that none of the parts are damaged, and clean the entire spindle with a soft, lint-free cloth.
- If oil, cutting fluid, or liquid itself has adhered to the product, or if the product is very dirty, clean it with a soft, lint-free cloth dipped in a volatile solvent (cleaning alcohol, etc.).
- After use, apply Micrometer Oil (Part No. 207000) to the entire spindle to prevent rust. In particular, if this product is used in places exposed to water-based cutting fluid, always apply anti-rust treatment after cleaning.
- If the product will not be used for three months or longer, apply Micrometer Oil (Part No. 207000) to the spindle to prevent rust, and store it with its battery removed.
- If Micrometer Oil is unavailable and the only option is a commercial product, we recommend low-viscosity anti-rust oil of ISO VG 10 or so.
- When storing the product, leave a gap of 0.2 to 2 mm between the measurement surfaces, and release the clamp.
 

3. Names of Components

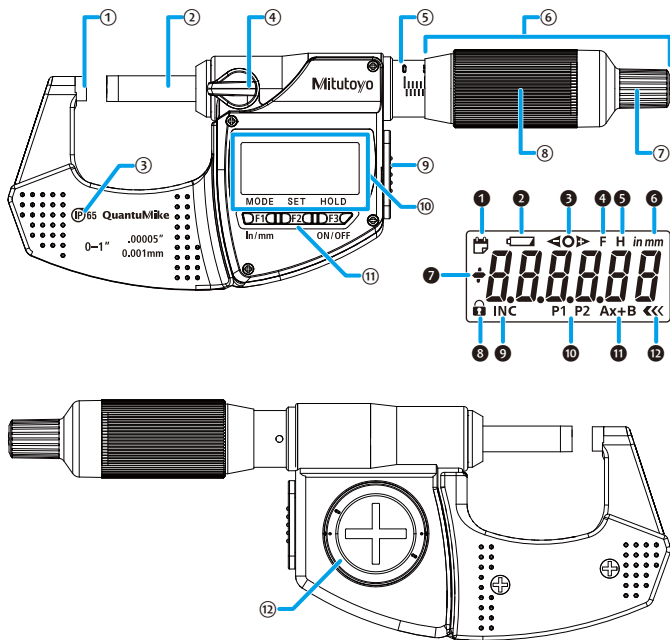

- ① Anvil
- ② Spindle
- ③ Waterproof mark
- ④ Clamp (locks the spindle to prevent motion)
- ⑤ Sleeve
- ⑥ Ratchet thimble (built-in constant-pressure device)
- ⑦ Speeder
- ⑧ Thimble
- ⑨ Cover (data output connector)
- ⑩ Display unit (LCD)
- ⑪ [F1] key, [F2] key, [F3] key
- ⑫ Battery compartment cover

- ① Calibration schedule alert indicator
- ② Low battery voltage indicator
- ③ Tolerance judgment indicators
- ④ Key customization function indicator
- ⑤ Hold indicator
- ⑥ in/mm indicator (inch models only)
- ⑦ Sign indicator
- ⑧ Function lock indicator
- ⑨ INC indicator
- ⑩ Preset indicators
- ⑪ Calculation function indicator
- ⑫ Approach speed function indicator

■ Key operation icons



4. Installing the Battery

NOTICE

Shows risks that could result in property damage.

Always align the battery compartment cover with the threads and attach it so that the seal does not protrude. The product may not display values properly or may malfunction if the battery compartment cover or seal is not attached correctly.

Important

- The battery is not installed in the product at purchase. Install the battery as follows.
- The set ORIGIN position is erased when the battery is reinstalled. Set the origin again. (See "5.6 Setting ORIGIN".)
- The settings configured in function setting mode are preserved even if the battery is reinstalled. (Except for the function lock function)

- 1 Insert a coin or similar object into the groove on the battery compartment cover, and turn it to the left (counterclockwise) to remove the cover.
- 2 Install the battery (CR2032) with the positive side facing up.
- 3 Position the battery compartment cover and turn it to the right (clockwise) to attach the cover.
 - » The power turns on, and [-----] is displayed.
 - When the calibration schedule alert function is ON, [todAy] is displayed. Proceed to step 4 in "7.8 Selecting the Calibration Schedule Alert [Cal.att]".
- 4 Briefly press the [F2] key.
 - » The counter is displayed, and counting starts.

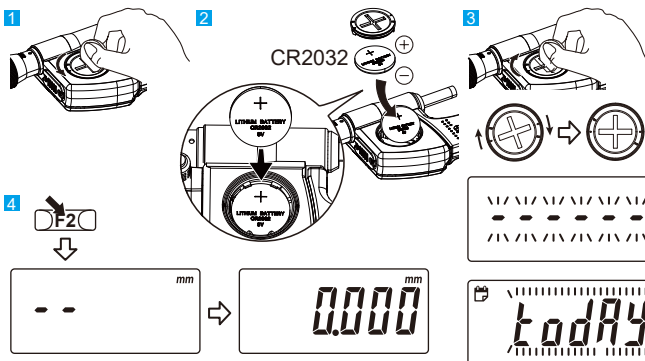

Tips

- Be sure to use a CR2032 battery (coin-shaped lithium battery).
- Do not rotate the ratchet thimble until the count value is displayed. The initialization of the electrical components may fail, and the product may not count properly. If you mistakenly move the ratchet thimble, remove the battery and reinstall it.
- If the display is abnormal, for instance an error is displayed or it is not counting, remove the battery and reinstall it.
- The battery supplied is for confirming the functions and performance of the product. Note that this battery may not fulfill the predetermined life.
- Malfunction or damage due to a depleted battery, etc., is not covered by the warranty.
- Follow local rules and regulations regarding battery disposal.

5. Common Operations

5.1 Turning the Power On and Off

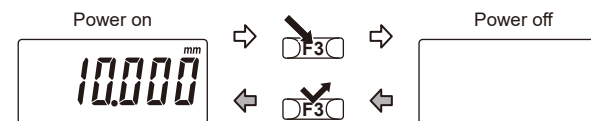

5.2 Switching the Units (mm/in; Inch Models Only)

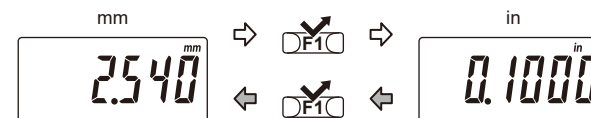

5.3 Switching the Measurement Type (ABS/INC)

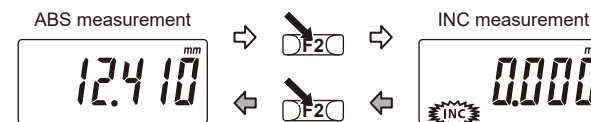

- ABS→INC: The [INC] indicator is displayed, and the display is set to zero.
- INC→ABS: The [INC] indicator disappears, and the length from the origin (anvil measurement surface) is displayed.

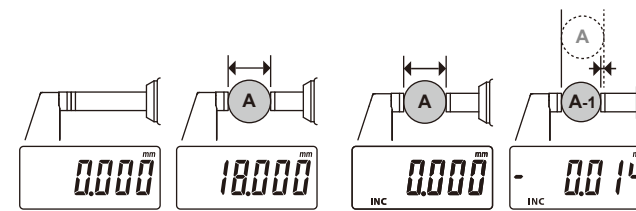

5.4 Setting the Display to Zero (in INC Measurement)



5.5 Setting/Releasing the Display-Value Hold

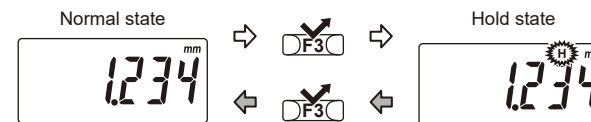

- Normal state: The [H] indicator is not displayed, and counting is performed normally.
- Hold state: The [H] indicator is displayed, and the displayed value is held.

5.6 Setting ORIGIN

Important

Perform the ORIGIN setting in the same orientation and conditions as when measuring.
Using a different orientation or conditions can cause measurement errors.

■ Models with a measurement range of 0 to 25 mm (0 to 1 inches / 0 to 25 mm)

- Clean both the anvil and spindle measurement surfaces to remove all debris and dust.
- Make light contact with both measurement surfaces, stop momentarily, and then apply the appropriate measuring force. (See "■ Precautions for measurement" in "2. Precautions for Use".)
- Briefly press the [F2] key.
 - » [P] blinks on the display, and [+000.000] is displayed.

Tips

If the INC mark is displayed in the lower left, press and hold the [F2] key to return to ABS measurement, and then briefly press it again to proceed with ORIGIN setting.

- Briefly press the [F2] key again.
 - » [P] disappears, and setting is complete.

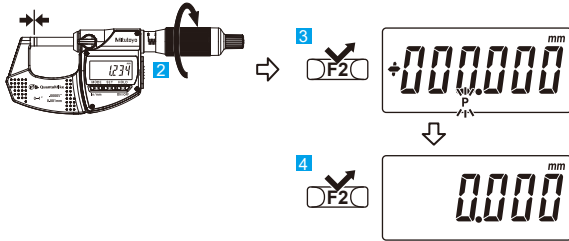

■ Models with a measurement range other than 0 to 25 mm (0 to 1 inches / 0 to 25 mm)

Use the micrometer standard bar (standard accessory) to perform the setting.

- Clean both the anvil and spindle measurement surfaces and the micrometer standard bar to remove all debris and dust.
- Place the micrometer standard bar between the measurement surfaces, bring both measurement surfaces into light contact with the bar, stop momentarily, and then apply the appropriate measuring force. (See "■ Precautions for measurement" in "2. Precautions for Use".)
- Briefly press the [F2] key.
 - » For models with a measurement range of 25 to 50 mm, [P] blinks on the display, and [+025.000] is displayed.
 - For models with a measurement range of 50 to 75 mm, [P] blinks on the display, and [+050.000] is displayed.
 - For models with a measurement range of 75 to 100 mm, [P] blinks on the display, and [+075.000] is displayed.

- Briefly press the [F2] key again.
 - » [P] disappears, and setting is complete.

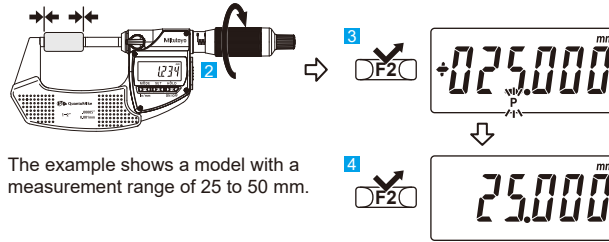

The example shows a model with a measurement range of 25 to 50 mm.

Tips

If the [F2] key is briefly pressed by accident while making a measurement, press and hold the [F1] key to return to the former state. If the product does not recover, perform "5.6 ORIGIN Setting" again.

■ Using a reference gage with a different size from the standard bar

Important

First, perform the ORIGIN setting normally.

- Clean both the anvil and spindle measurement surfaces and the reference gage you will use to remove all debris and dust.
- Turn the ratchet thimble until the size of the reference gage being used is displayed.
- Briefly press the [F3] key.
 - » [H] is displayed, and the displayed value is held.
- Briefly press the [F2] key.
 - » [P] blinks on the display.
- Place the reference gage between the measurement surfaces, bring both measurement surfaces into light contact with the gage, stop momentarily, and then apply the appropriate measuring force. (See "■ Precautions for measurement" in "2. Precautions for Use".)
- Briefly press the [F2] key again.
 - » [P] disappears, and setting is complete.

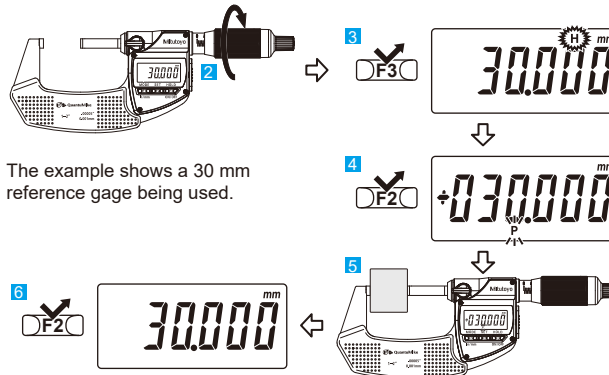

The example shows a 30 mm reference gage being used.

6. Measurement Method

Important

Bring the measurement surface of the spindle slowly and gently into contact with the workpiece. Moving too quickly could deform the workpiece and affect measurement results.
(See "■ Precautions for measurement" in "2. Precautions for Use".)

- Perform the ORIGIN setting. (See "5.6 Setting ORIGIN".)
- Slowly bring the measurement surfaces into light contact with the workpiece in the same orientation and conditions as when the origin was set, and apply the appropriate measuring force. (See "■ Precautions for measurement" in "2. Precautions for Use".)
- Read the displayed value.

ABS measurement

INC measurement

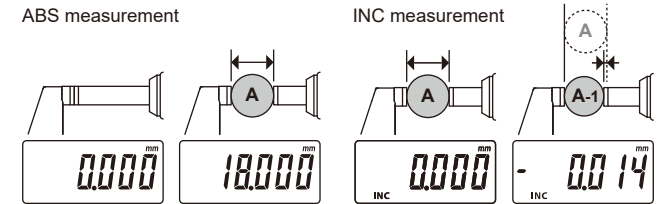

● Key operation and function list

Key	Press length	Measurement type	Function
F1	[F1]	ABS	Switch between in/mm (inch models only)
		INC	
F2	[F2]	ABS	Change to the function setting mode
		INC	
F3*	[F3]	ABS	Set a preset value
		INC	Set the display to zero
	[F2]	ABS	Switch to INC measurement and set the display to zero
		INC	Switch to ABS measurement
[F3]	ABS	Set/release the display-value hold	
	INC	Power off	

* When the power is off, briefly pressing this key turns on the power.

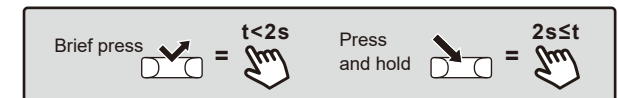

7. Other Operations

7.1 Selecting the Function Setting Mode

Switch from measurement mode to the function setting mode, and select the desired setting mode. See the following sections for details about each of the setting modes.

When resetting the settings, perform "Reset all" instead of removing and reinstalling the battery. (See "7.11 Resetting All Settings [reset]".)

Measurement mode

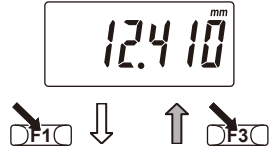

Tips

To cancel a setting, press and hold the [F1] key on the first screen of any setting mode.

Function setting mode

Change the units (inch models only) [unit] → [F1] ✓

Reset all [reset] ← [F3] ✓

Tolerance judgment [tol.] ← [F3] ✓

Auto OFF function [A-off] ← [F1] ✓

Calculation function [calc.] ← [F3] ✓

Auto ON function [A-on] ← [F1] ✓

Approach speed [A-S] ← [F3] ✓

Calibration schedule alert [Cal.alt] ← [F1] ✓

Key customization [S-sel] → [F3] ✓

Function lock [F-loc] ← [F1] ✓



Change to execution of each setting mode.

7.2 Changing the Units [unit]



Switch which units are displayed. This function can be executed only with inch models.

- Briefly press the [F2] key.
 - » The units can be changed.
- Briefly press the [F3] key or the [F1] key.
 - » The unit (mm/in) is switched.
- Briefly press the [F2] key.
 - » The setting is applied, and the next setting item is displayed.

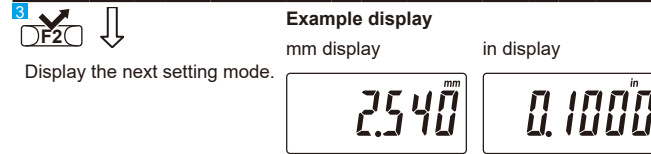
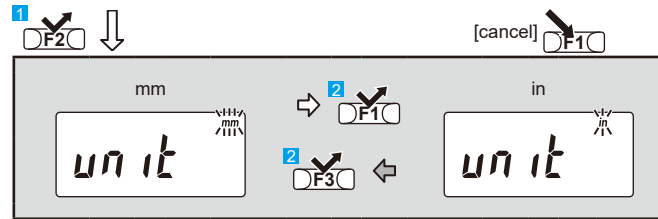

7.3 Performing Tolerance Judgment [tol.]



This function judges whether the measured value is within the set lower and upper tolerance limits, and the result is displayed as an icon.

Important

When enabling tolerance judgment, be sure to set both the upper and lower tolerance limits.

- Briefly press the [F2] key.
 - » The tolerance judgment settings can be changed.
- Briefly press the [F3] key or the [F1] key.
 - » Tolerance judgment is toggled (on/off).
- When turning the function on, briefly press the [F2] key.
 - » The upper and lower tolerance limits can be set.
- After you set the upper and lower tolerance limits, briefly press the [F2] key.
 - » The setting is applied, and the next setting item is displayed.

Setting a number and moving among digits

Example display

When the lower tol. limit value is set to 10.000 mm and the upper tol. value is set to 10.010 mm

-NG : 9.998^{mm}

OK : 10.003^{mm}

+NG : 10.012^{mm}

7.4 Using the Calculation Function [calc.]



The function $Ax+B$ multiplies the counter value (x) by a coefficient A and then adds another coefficient B to that product. The [Ax+B] is displayed while this function is active.

Important

When enabling the calculation function, be sure to set the coefficients.

- Briefly press the [F2] key.
 - The calculation function settings can be changed.
- Briefly press the [F3] key or the [F1] key.
 - The calculation function is toggled (on/off).
- When turning the function on, briefly press the [F2] key.
 - Coefficient A and coefficient B can be set.
- After you set coefficient A and coefficient B, briefly press the [F2] key.
 - The setting is applied, and the next setting item is displayed.

Calculation function off → Calculation function on

Coefficient B setting (+B) → Coefficient A setting (+A)

For details about setting the numbers and moving among the digits, see the procedure in "7.3 Performing Tolerance Judgment [tol.]".

Example display

When coefficient A is set to 0.5, coefficient B is set to 5.000, and the counter value is 2.012 mm



7.5 Selecting the Approach Speed Warning Function [A-S]

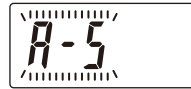

This function calculates the movement speed of the spindle just before it makes contact with the workpiece from the counting speed of the display, and if the speed exceeds a threshold, the displayed

value blinks to warn the operator.

◀◀◀ is displayed in the lower right while this function is active.

- Briefly press the [F2] key.
 - The approach speed settings can be changed.
- Briefly press the [F3] key or the [F1] key.
 - The approach speed warning function is toggled (on/off).
- Briefly press the [F2] key.
 - The setting is applied, and the next setting item is displayed.

Example display

Display the next setting mode.

Active: 4996 mm ◀◀◀

Alarm activated: 4996 mm ◀◀◀

Clearing the warning (stop blinking)

Widen the gap in the measurement surfaces by 0.5 mm or more (rotate the thimble by 1/4 of a rotation or more).

7.6 Customizing the Key Operation Settings [S-sel]



This function lets you change the functions that are assigned to the operation keys according to your usage. All three operation keys are changeable. [F] is displayed while this function is active.

List of customizable settings

[none]	: Default setting	
[unit] ^{*1}	: Switch the units (mm/in)	*1: [F1] key of inch models only
[zero]	: Zero setting	*2: The set preset value is displayed.
[p.call]	: Preset recall ^{*2}	
[Calc.on]	: Toggle the calculation function on/off	

- Briefly press the [F2] key.
 - The key operation settings can be customized.
- Briefly press the [F3] key or the [F1] key.
 - The key operation setting is toggled (default/customized).
- When [custom] is selected, briefly press the [F2] key.
 - The [F1] key operation setting can be customized.
- After you have customized the key operation settings of the [F1] key, [F2]

key, and [F3] key, briefly press the [F2] key.

» The setting is applied, and the next setting item is displayed.

Default setting [def] → Customized setting [custom]

[F1] key setting → [F1]

[F2] key setting → [F2]

[F3] key setting → [F3]

[F1] key setting: none, unit, zero, p.cAll, cALcon

[F2] key setting: none, zero, p.cAll, cALcon

[F3] key setting: none, hold, zero, p.cAll, cALcon

Example display: 5.006 mm

7.7 Preventing Accidental Operation by Locking the Functions [F-loc]



This function prevents accidental operation. Operations other than power on/off, display-value hold/release, display-value output, and function lock release cannot be performed.

[] is displayed in the lower left while this function is active. This setting is reset to "off" when the battery is reinstalled.

- Briefly press the [F2] key.
 - » The function lock settings can be changed.
- Briefly press the [F3] key or the [F1] key.
 - » The function lock is toggled (on/off).
- Briefly press the [F2] key.
 - » The setting is applied, and the next setting item is displayed.

Example display

Display the next setting mode.

7.8 Selecting the Calibration Schedule Alert [Cal.alt]



This function notifies the operator of the calibration period with a warning display. After setting the current date, the alert date, and the calibration date, a "warning" and a "calibration period warning" are displayed.

[] is displayed in the upper left while this function is active.

- Briefly press the [F2] key.
 - » The calibration schedule alert settings can be changed.
- Briefly press the [F3] key or the [F1] key.
 - » The calibration schedule alert is toggled (on/off).
- When turning the function on, briefly press the [F2] key.
 - » The current date can be set.
- Set the current date, the calibration date, and the alert date.
- Briefly press the [F2] key.
 - » The setting is applied, and the next setting item is displayed.

Example display

Display the next setting mode.

4 Current date setting



5

Set the tens digit



Set the ones digit



[year] setting



Set the tens digit



Set the ones digit



[month] setting



Set the tens digit



Set the ones digit



[day] setting



Calibration date setting



Set the tens digit



Set the ones digit



[year] setting



Set the tens digit



Set the ones digit



[month] setting



Set the tens digit



Set the ones digit



[day] setting



Alert date setting



Set the tens digit



Set the ones digit



[year] setting



Set the tens digit



Set the ones digit



[month] setting



Set the tens digit



Set the ones digit



[day] setting



[year] setting

Tens digit

Can be set from 2022.

9 ← 8 → 7 ← 6 → 5 ← 4 → 3 → 2

One digit

9 ← 8 → 7 ← 6 → 5 ← 4 → 3 → 2 → 1 → 0

[month] setting

Tens digit

1 ← 0

One digit (when the tens digit is 0)

9 ← 8 → 7 ← 6 → 5 ← 4 → 3 → 2 → 1

One digit (when the tens digit is 1)

2 ← 1 → 0



[day] setting

Tens digit

3 ← 2 → 1 → 0

One digit (when the tens digit is 0)

9 ← 8 → 7 ← 6 → 5 ← 4 → 3 → 2 → 1

One digit (when the tens digit is not 0)

9 ← 8 → 7 ← 6 → 5 ← 4 → 3 → 2 → 1 → 0



Display the next setting mode.

Example display



Active



Advance warning activated



Calibration period warning activated

7.9 Selecting the Auto ON Function [A-on]



When the power is off, this function automatically turns on the power when the spindle or a key is operated.

When this function is not selected, briefly press the [F3] key to turn on the power.

- 1 Briefly press the [F2] key.
 - » The Auto ON function settings can be changed.
- 2 Briefly press the [F3] key or the [F1] key.
 - » The Auto ON function is toggled (on/off).
- 3 Briefly press the [F2] key.
 - » The setting is applied, and the next setting item is displayed.

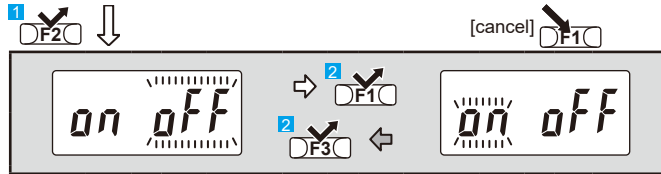

- 3 ↓
Display the next setting mode.

7.10 Selecting the Auto OFF Function [A-off]



This function automatically turns off the power after about 20 minutes of inactivity. When this function is not selected, press and hold the [F3] key to turn off the power.

- 1 Briefly press the [F2] key.
 - » The Auto OFF function settings can be changed.
- 2 Briefly press the [F3] key or the [F1] key.
 - » The Auto OFF function is toggled (on/off).
- 3 Briefly press the [F2] key.
 - » The setting is applied, and the next setting item is displayed.

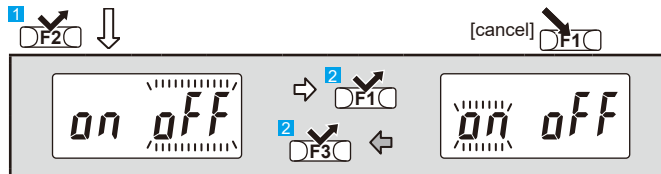

- 3 ↓
Display the next setting mode.

7.11 Resetting All Settings [reset]



This function resets the settings of all functions to their factory default state.



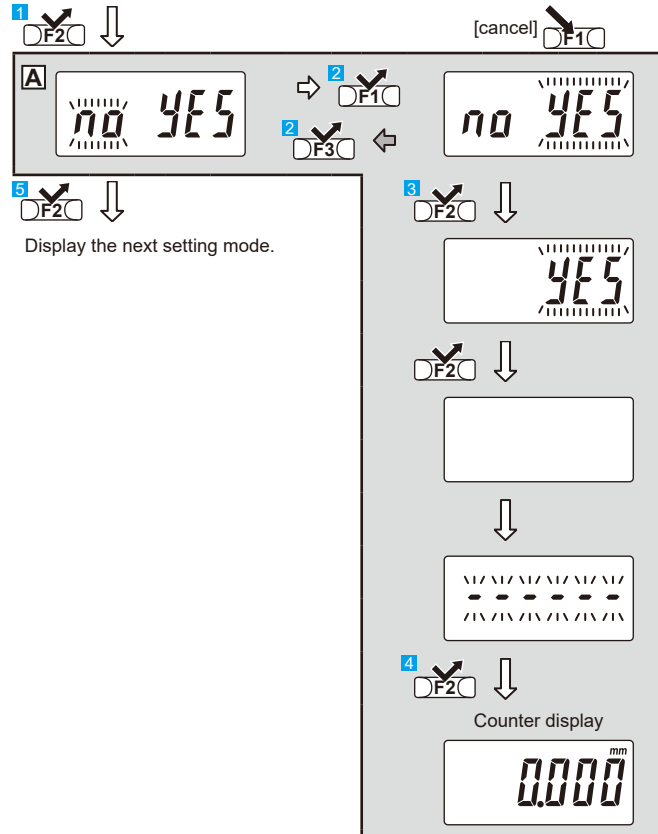





- 1 Briefly press the [F2] key.
 - » The reset all function can be selected.
- 2 Briefly press the [F3] key or the [F1] key.
 - » Execution of reset all is toggled (yes/no).
- 3 If you select [yes], briefly press the [F2] key again to confirm your choice.
 - » The reset all function is executed, and the display returns to its initial state.
- 4 Briefly press the [F2] key.
 - » The counter is displayed, and counting starts.
- 5 Briefly press the [F2] key.
 - » The setting is applied, and the next setting item is displayed.





● Factory default state

Name	Setting value
Units (mm/in) setting (inch models only)	Inch models: in setting Millimeter models: mm setting
Measurement type setting	ABS measurement
Preset value	Set to the ORIGIN value for each device type
Tolerance judgment function setting	Off
Calculation function setting	Off
Approach speed warning	Off
Operation key customization setting	Off
Function lock function	Off
Calibration schedule alert function	Off
Auto ON function setting	On
Auto OFF function setting	On

8. Error Displays and Troubleshooting

Error display	Causes and countermeasures
Battery voltage drop 	The battery voltage is low. Replace the battery promptly.
Over-speed error 	A counting error occurred due to over-speed or noise. • Press the [F2] key to return to measurement mode, and perform the ORIGIN setting again. • If [] is displayed, remove and reinstall the battery, then perform the ORIGIN setting again.
Display-value overflow error 	The displayed value exceeded the range that can be displayed. Return the displayed value to the number of displayable digits. The error will be cleared automatically.
Sensor error 	Something caused an abnormality in the sensor. Remove the battery and reinstall it. If the problem persists, the product may be malfunctioning. Please contact the agent where you purchased the product or a Mitutoyo sales office.
Forced serial communication error 	The serial communication command [B7] (forced error display) was received. Send the serial communication command [B8] (error clear).
Forced calibration schedule alert error 	The serial communication command [89] (forced calibration schedule alert display) was received. Send the serial communication command [89] (forced calibration schedule alert display).
Corrupt memory error 	Something caused the memory to become corrupted. Remove the battery and reinstall it. If the problem persists, the product may be malfunctioning. Please contact the agent where you purchased the product or a Mitutoyo sales office.
Internal program abnormality error 	An abnormality occurred in the internal program, and measurement could not be performed. The product may be malfunctioning. Please contact the agent where you purchased the product or a Mitutoyo sales office.

Error display	Causes and countermeasures
Upper/lower tolerance limit setting error 	The upper tolerance limit value is smaller than the lower tolerance limit value. Set the upper tolerance limit value to a value greater than the lower tolerance limit value.
Coefficient setting error 	Coefficient A is set to zero. Set coefficient A to a value other than zero.
Calibration date setting error 	The calibration date and the alert date are set earlier than the current date. Set the dates such that current date < alert date < calibration date.

9. Specifications

Maximum measuring length:	25 mm, 50 mm, 75 mm, 100 mm 1 in, 2 in, 3 in, 4 in
Maximum permissible error J_{MPE}^{*1} :	$\pm 1 \mu\text{m}$ (maximum measuring length: 25 mm, 50 mm), $\pm 2 \mu\text{m}$ (maximum measuring length: 75 mm, 100 mm) $\pm 0.00005 \text{ in}$ (maximum measuring length: 1 in, 2 in) $\pm 0.00010 \text{ in}$ (maximum measuring length: 3 in, 4 in)
Measuring force ^{*2} :	7 N to 12 N
Resolution:	0.001 mm, 0.00005 in
Display unit:	LCD (6 digits and minus sign)
Power:	Coin-shaped lithium battery (CR2032) x 1
Battery life:	About 2 years
Temperature range:	5 °C to 40 °C (operating temperature), -10 °C to 60 °C (storage temperature)
Standard accessories:	Wrench (No. 301336), Standard bar (only products with a measuring length exceeding 25 mm (1 in))
IP protection level:	IP65 (refer to IEC60529 and JIS C 0920 for details) Dust resistance (level 6): No ingress of dust allowed Protection against water jets (level 5): Water projected by a nozzle from any direction shall have no harmful effects.
CE marking / UKCA marking:	EMC Directive / Electromagnetic Compatibility Regulations: EN IEC 61326-1 Immunity test requirement: Clause 6.2 Table 2 Emission limit: Class B RoHS Directive / Restriction of the Use of Certain Hazardous Substances in Electrical and Electronic Equipment Regulations: EN IEC 63000
*1:	Maximum permissible error for indicated value via contact with full measuring face J_{MPE} (20 °C).
*2:	Measuring force when holding the speeder and turning the ratchet thimble.

10. Input/Output Functions

For input/output functionality, the product has both DIGIMATIC d1 (output) and DIGIMATIC S1 (input/output).

- DIGIMATIC d1: 6-digit output for Mitutoyo DIGIMATIC products
- DIGIMATIC S1: Bidirectional serial I/O for Mitutoyo DIGIMATIC products

Important

To perform bidirectional serial communication via DIGIMATIC S1, the measurement data collection software option USB-ITPAK (V3.0 or later) and the VCP driver option must be installed on a PC, and this product must use one of the following optional accessories and be connected to the PC via USB.

- USB Input Tool IT-020U (Part No. 264-020) and connection cable (06AGL111/06AGL121)
- USB Input Tool Direct USB-ITN-SA (Part No. 06AGQ001A)

For details, see the instruction manual for the relevant optional accessory.

■ Attaching/removing the cable

This section explains how to attach and remove the cable (optional connection cable and USB Input Tool Direct USB-ITN-SA).

NOTICE

Shows risks that could result in property damage.

- Waterproof functionality may decrease and lead to malfunctions. Please pay attention to the following.
 - Make sure that the connector gasket does not protrude while fixing the cover and cable with the screws.
 - Be sure to use the 0-size Phillips screwdriver (No. 05CZA619) supplied with the cable when attaching/removing screws, and tighten them with a torque of about 8 to 10 cN·m.
 - When attaching or removing the cable, do not grip the cable part. Doing so could damage the cable.

Important

Note that using this product in a location with high noise may cause malfunctions (flickering or errors).

When removing the cable, follow these steps in reverse order.

- 1 Use the 0-size Phillips screwdriver supplied with the cable option to remove the cover fixing screws (M2.0 x 3.0, No. 04AAC626).
- 2 Remove the cover.
- 3 Check that the connector gasket (No. 04AAC625) is correctly installed at the proper position (do not remove the connector gasket).
- 4 When connecting the cable, pay attention to the orientation of the connector (align the ▲ marks), and insert the cable straight and securely while holding the connector.
- 5 Tighten the fixing screws.

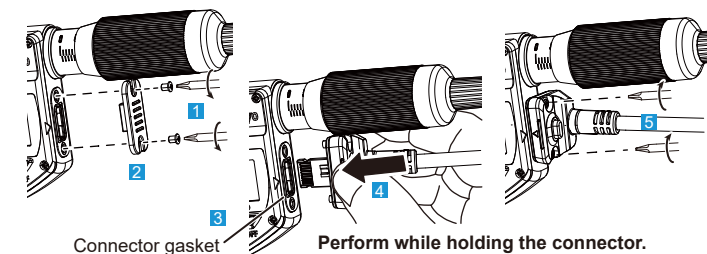

Output via DIGIMATIC d1

The displayed value (max. 6 digits) can be output to an external device by connecting this product and the device with the connection cable option.

Output data format

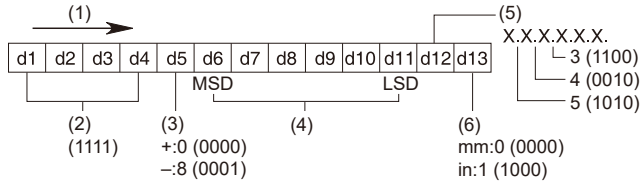

(1) Output order, (2) All "F", (3) Sign, (4) Measured value, (5) Decimal point, (6) Unit

Timing chart

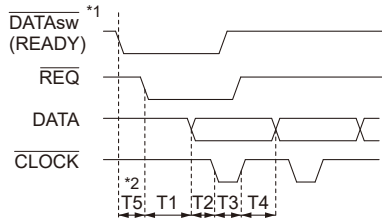

$0 \text{ ms} \leq T1 \leq 200 \text{ ms}$
 $0.11 \text{ ms} \leq T2 \leq 0.14 \text{ ms}$
 $0.11 \text{ ms} \leq T3 \leq 0.14 \text{ ms}$
 $0.22 \text{ ms} \leq T4 \leq 0.27 \text{ ms}$
 $T5 \leq 80 \text{ ms}$

*1: DATAsw is LOW while the data output key is being pressed.

*2: The time T5 until DATAsw switches to LOW and REQ is input is determined by the performance of the data processing device.

Input/Output via DIGIMATIC S1

The following operations can be performed by connecting to a PC in which the optional measurement data collection software "USB-ITPAK V3.0" has been installed via the input tool.

- Collection of measurement results of this product
- Collection of information such as the serial number of this product
- Settings for this product, such as zero set, preset, and tolerance judgment

Tips

Switching the approach speed warning function and the Auto ON function ON and OFF is not supported.

11. Optional Accessories

- Connection cable (1 m) : No. 06AGL111
- Connection cable (2 m) : No. 06AGL121

For optional accessories other than those above, refer to the Mitutoyo General Catalog.

12. Off-Site Repairs (Subject to Charge)

Off-site repair (subject to charge) is required in the case of the following malfunctions. Please contact the agent where you purchased the product or a Mitutoyo sales office.

- Faulty spindle operation
If the spindle is scratched, these scratches may interfere while the spindle is retracting, causing faulty operation.
Operation may also suffer if the spindle is rusted.
- Inconsistent measured values
Burrs or nicks generated by an impact on the measurement surfaces may affect measurement repeatability.
- Count value error/faulty operation
If the thimble of this product is retracted too far, the internal sensor will be damaged. This may cause count errors or faulty operation.